



USA Swimming Southern Zone Meeting

September 12, 2020
Virtual Meeting

Zone Directors:

Dave Smith - Non-Coach
Jim Kelly - Coach

Zone Secretary/Treasurer - Herb Schwab
Zone Age Group Chair - Jonathan Watson
Zone Senior Chair - Matt Webber

Zone Open Water Coordinator - Nick Graves

Zone Officials Coordinator - Trish Martin/Traci Johnson
Zone Senior Athlete Representative - Annie Norris
Zone Junior Athlete Representative - Ryan Gibbons

Call to order by Dave Smith, Zone Director, on Saturday, September 12, 2020, at 3:00 p.m. Eastern Time.

Roll Call - Herb Schwab

15 LSCs in attendance with 147 delegates. All LSCs were present.

LSC	Del	Ath	LSC	Del	Ath
Border	X		North Carolina	X	X
Florida	X	X	North Texas	X	X
Florida Gold Coast	X		South Carolina	X	
Georgia	X	X	South Texas	X	X
Gulf	X	X	Southeastern	X	X
Kentucky	X		West Texas	X	X
Louisiana	X	X	West Virginia	X	
Mississippi	X	X			

Introduction of Zone Officers

Dave Smith introduced each of the Zone Officers. All of the Zone Officers were present.

Agenda distributed and approved

This year, in a continuing effort to be eco-friendly, the Agenda, Minutes, and all of the Handouts were posted on the Southern Zone website, and notifications were emailed to all of the LSCs and each Southern Zone Delegate registered for the USAS Convention. Each LSC was also asked to forward the electronic files to their delegates. No paper copies were distributed, since this meeting is being held remotely. The agenda was approved.

Approval of 2019 Meeting Minutes

Motion was made and seconded to approve the minutes of the 2019 Convention meeting. Motion carried.

Reports of Officers, Committees and Others:

Dave Smith, Non-Coach Zone Director

Dave reported that most of the Officers' and Chairs' reports have been posted on the Southern Zone website. A few specific reports will be presented during this meeting.

Herb Schwab, Secretary/Treasurer

Herb reported that the Southern Zone account balance is \$17,636.90, which includes the earmarked funds for Diversity, Equity, and Inclusion of \$5,204.57. The Financial Report is on the Southern Zone website and is attached.

Trish Martin/Traci Johnson, Officials Chair

Trish's report on the activities of the Zone Officials is on the Southern Zone website and is attached. Trish recognized and thanked the Meet

Referees of the Spring Sectional Meets. There were no Summer Sectionals nor Zone Championship Meets this year.

Annie Norris, Senior Athlete Representative Annie's report on the activities of the Athletes Representatives is on the Southern Zone website and is attached.

The Athletes conducted weekly video meetings this year, along with a virtual workshop and other engagement-type events. The Athletes focused on getting the athletes organized and involved, using the video meetings and social media. The virtual workshop videos are available on the Zone website.

Ryan Gibbons, Junior Athlete Representative Ryan reported on the upcoming Athlete Representatives elections, which will be held tomorrow. The Athletes spent this past year getting organized as a committee and will focus on goals to serve the athletes, General Chairs, and LSCs for this upcoming year. The Athletes will also focus on DE&I efforts for this coming year. The athletes will work on an Athlete Workshop for 2021, which may be held virtually again.

[After this meeting adjourned, Ryan Gibbons (FL) was elected as the Senior Athlete Representative for a two-year term. Lauren Hurt (SE) was elected as the Junior Athlete Representative for a one-year term.]

USA Swimming Leadership Presentations Bob Vincent, Mike Unger, and Joel Shinofield addressed the Zone Delegates.

Mike updated the Delegates about the Virtual Convention for this year. At this time, there are over 800 delegates registered. Mike discussed the Convention topics, the Agenda, and the House of Delegates meetings. Everything is posted on the USA Swimming website, along with all of the Committee Meeting Notices.

Mike also updated the Delegates with information about Olympic Trials in Omaha in 2021. There are backup plans, in case of issues with the Omaha venue. The dates are one week earlier than were scheduled for 2020, but the TV coverage should include more hours. Currently, the Trials Cuts are the same, but those cuts will be re-evaluated later this year.

Bob updated the Delegates about meet sanctioning issues. Hopefully, the LSCs will have the full authority to sanction meets in the near future.

Joel updated the Delegates about the weekly, and subsequently monthly, LSC meetings that have been held. The Board will be reviewing the plans for the fall national meets. Winter Juniors will probably be organized in a de-centralized fashion where each LSC can host their own competition to avoid large gatherings and long travel. Each LSC will have the flexibility to host the meet as best fits their needs. The US Open will probably be held at several locations, probably 6-10 locations, to conform to the smaller gathering restrictions.

2021 Southern Zone Age Group Championships Date and Site

The dates for 2021 set at last year's Convention:
July 27-31, 2021 Tupelo, MS (MS)

2021 Southern Zone Senior Championships Date and Site

The dates for 2021 set at last year's Convention:
July 27-31, 2021 College Station, TX (GU)

2021 Southern Zone Open Water Championships Date and Site

The dates for 2021 will be:
May 28-30, 2021 Chattanooga, TN (SE)

Nominations

Zone Director – Non-Coach: Dave Smith (SE)
No other candidates were nominated.

Zone Secretary/Treasurer: Herb Schwab (GU)
No other candidates were nominated.

Zone Age Group Chair: Jonathan Watson (NC)
No other candidates were nominated.

A Motion was made and seconded to elect all of the three positions by acclamation. Motion carried.

Dave Smith was elected as the Zone Director - Non-Coach.

Herb Schwab was elected as the Zone Secretary/Treasurer.

Jonathan Watson was elected as the Zone Age Group Chair.

2022 Southern Zone Age Group Championships Dates and Site Nominations/Presentations

The proposed dates for 2022 are:
July 26-30, 2022

A motion was made and seconded to approve these dates. Motion carried.

Two bids for the 2022 Southern Zone Age Group Championships were received from:

Shockwave Aquatics Team	Tupelo, MS (MS)
Arlington ISD Aquatic Club	Arlington, TX (NT)

The bidders were allowed to make presentations (attached). The vote on the site for these Championships will be held during the Southern Zone Meeting on September 27.

2022 Southern Zone Senior Championships Dates and Site Nominations/Presentations

The proposed dates for 2022 are:
July 26-30, 2022

A motion was made and seconded to approve these dates. Motion carried.

Three bids for the 2022 Southern Zone Senior Championships were received from:

Shockwave Aquatics Team	Tupelo, MS (MS)
Arlington ISD Aquatic Club	Arlington, TX (NT)
Club Mountaineer Aquatics	Morgantown, WV (WV)

The bidders were allowed to make presentations (attached). The vote on the site for these Championships will be held during the Southern Zone Meeting on September 27.

The Delegates asked the presenters several questions concerning the scoreboard capabilities of each venue, and the air quality of each venue.

2022 Southern Zone Open Water Championships Dates and Site Nominations/Presentations

One bid for the 2022 Southern Zone Open Water Championships was received.

Ft. Myers, FL (FL)

Probably late April 2021

Jaime Lewis, USA Swimming Sport Development/Southern Zone Consultant

Jaime Lewis updated the Delegates about her role as the Southern Zone Sport Development Consultant.

Old Business

There was no Old Business to consider.

New Business

Dave reported on the Zone Officials that have been included on the FINA list. Congratulations to Jason Johnson as a FINA Starter and Trish Martin as a FINA Referee.

Jim discussed some upcoming rules proposals that will modify the Sectional Meet requirements and the sizes of the Sectional Meets. These requirements have been added to the working copy of the Zone Policies and Procedures.

There is a proposed rule that would eliminate the Zone Bylaws and require the Zones to have a Policies and Procedures Manual. Dave and Jim are in the process of merging our current Bylaws and Policies and Procedures into one document. If this rule change passes, Dave and Jim will send out the proposed changes to the Delegates for their input and the Zone will vote on the changes at a later meeting.

Dave proposed changing the Open Water Chair position to an elected, voting position in the Zone. This change will be voted on during the September 27th meeting.

Announcements

Dave announced that Rayleen Soderstrom has been re-appointed as the SZ Disability Coordinator.

Don Henshaw continues to do a great job as the SZ Webmaster.

Zone Diversity, Equity, and Inclusion Camps will now be conducted by USA Swimming. The information for these camps has been distributed to the LSCs and more information may be obtained from Ruth Ann Bode or MJ Truex.

Annie Norris has been instrumental in conducting weekly ZOOM Meetings with the LSC Athlete Representatives. She and Ryan Gibbons have been instrumental in conducting a very successful SZ Athlete Workshop. She is now working as the AEC Programming and Events Chair, but will still be available as a valuable mentor to our SZ Athletes.

Elections for the SZ Senior and Junior Athlete Representatives will be conducted tomorrow and they will be introduced to the Delegates at our meeting on September 27th.

Herb asked all of the Sections to email their dates and locations for the 2021 Sectional Meets to him by the September 27th meeting.

Dave reminded the Delegates that the next meeting of the Southern Zone will be held on Sunday, September 27, at 7 pm Eastern Time, when we will vote on the sites of the Zone Championships and the change in the Open Water Chair position. The LSCs have the opportunity to use the next two weeks to discuss their voting

preferences. There will not have any ZOOM Breakout Rooms during that meeting.

Motion to Adjourn was made and seconded at 4:20 p.m. Eastern Time. Motion carried.

Respectfully submitted,

A handwritten signature in black ink that reads "H. B. Schwab". The signature is written in a cursive style with a large, looped initial "H".

Herb Schwab
Secretary/Treasurer
Southern Zone

Southern Zone
Financial Report
September 2020

Previous Balance as of 9/2019		\$13,419.32
Interest for Year 2019	\$63.85	
Annual Membership Dues - Year 2020	<u>\$750.00</u>	
Total Income		\$813.85
9/18/19 Zoom Videoconference License	\$159.80	
8/6/20 Athlete Workshop	<u>\$1,641.04</u>	
Total Expenses		\$1,800.84
General Fund Balance as of 9/2020		\$12,432.33
Diversity, Equity & Inclusion Funds		\$5,204.57
Total Balance of Southern Zone Funds		\$17,636.90



Southern Zone Officials Coordinator Report

September 2020

1) Thank you to the meet referees for our Spring Sectional meets:

- ESSZ Senior Sectionals at TAC—Rob Stevens, NC
- SSSZ Senior Sectionals at Plantation—Hector Acevedo, FG
- WSSZ Senior Sectionals at College Station—Rick Tobin, GU
- ESSZ Age Group Sectionals at GA Tech—Neal McKinney, GA

NOTE 2020 Summer Sectionals and Zone Championships were cancelled.

2) Total number of Southern Zone officials held fairly steady in 2019 versus the prior year. The Officials/Athletes ratio bumped up on reduced swimmer membership.

Southern Zone Officials by LSC												
LSC	Officials				Year Round Athletes				Officials as % of Athletes			
	2016	2017	2018	2019	2016	2017	2018	2019	2016	2017	2018	2019
Border	51	44	45	49	836	895	915	840	6.1%	4.9%	4.9%	5.8%
Florida	400	424	429	461	10881	11581	11150	10349	3.7%	3.7%	3.8%	4.5%
Florida Gold Coast	178	204	201	223	5300	5685	5077	5053	3.4%	3.6%	4.0%	4.4%
Georgia	313	292	315	305	7571	8163	8007	7836	4.1%	3.6%	3.9%	3.9%
Gulf	365	394	432	377	9066	10158	10013	9098	4.0%	3.9%	4.3%	4.1%
Kentucky	281	260	258	226	2869	2766	2615	2324	9.8%	9.4%	9.9%	9.7%
Louisiana	140	120	120	127	3181	2986	2852	2834	4.4%	4.0%	4.2%	4.5%
Mississippi	88	82	96	79	1486	1567	1390	1049	5.9%	5.2%	6.9%	7.5%
North Carolina	498	531	563	569	9801	9984	10323	9669	5.1%	5.3%	5.5%	5.9%
North Texas	163	191	227	224	6806	7252	7364	7200	2.4%	2.6%	3.1%	3.1%
South Carolina	168	187	193	191	3097	3314	3219	3208	5.4%	5.6%	6.0%	6.0%
South Texas	163	184	182	206	8129	8818	8484	8031	2.0%	2.1%	2.1%	2.6%
Southeastern	522	541	514	512	7737	8238	7969	6900	6.7%	6.6%	6.4%	7.4%
West Texas	29	30	33	33	891	963	948	703	3.3%	3.1%	3.5%	4.7%
West Virginia	41	50	47	47	640	695	622	472	6.4%	7.2%	7.6%	10.0%
Total	3400	3534	3655	3629	78291	83065	80948	75566	4.3%	4.3%	4.5%	4.8%

- 3) The Southern Zone now has 45 N3i/N3f evaluators including 4 new N3i evaluators in the past year.
- 4) Twenty-one Southern Zone officials have been invited to officiate at the 2021 Olympic Team Trials including eight in assigned positions plus the Meet Referee.
- 5) Eight Southern Zone officials are on the current and upcoming lists of FINA officials.

Respectfully submitted,

Trish Martin (NC)
Southern Zone Officials Coordinator

Traci Johnson (NT)
Southern Zone Assistant Officials Coordinator

8/31/2020

Southern Zone Athlete Workshop 2020 Report

On July 11, 2020, the Southern Zone Athlete Representatives hosted the first-ever Southern Zone Athlete Workshop, intended to develop professional and personal skills across our LSC Athlete Representatives. The event, occurring from 2-7:30PM ET, occurred entirely via Zoom (including the use of Breakout Rooms), and made use of software such as Mural and Google Forms to enhance the athletes' experience.

Planning & Development

Planning and execution of the Workshop was primarily the task of the Workshop Task Force, consisting of Annie Norris (Zone Sr. Rep), Ryan Gibbons (Zone Jr. Rep), Ellery Parish (Senior Mentor), Matthew Rigsbee (Media & Engagement), Annika Reuhlicke (Administrative Consultant), and Lauren Hurt (LSC Rep Consultant). After over two years of ideation, tangible planning for the Workshop started in April of 2020, and an estimated 250-300+ total man-hours of work by athlete volunteers ultimately resulted in such a successful turnout.

Non-athlete support was given by Dave Smith (SZ Non-Coach Director), Jim Kelly (SZ Coach Director), Herb Schwab (SZ Secretary/Treasurer), Kathleen Klein Prindle (USA-S Board Member), and Kenneth Chung (USA-S Board Member), both before and during the Workshop.

Content & Curriculum

The Workshop was designed to be complementary to existing athlete leadership curricula, focusing instead on tangible skills specific to the role of an Athlete Representative and the athletes' future professional careers. Athletes were encouraged to enter the Workshop with workable ideas for projects, legislation, or events relevant to their LSC, with the intent that the Workshop would provide them with skills and guidance necessary to grow, develop, and execute upon this idea.

In the weeks leading up to the Workshop, each individual LSC athlete cohort met briefly with a member of the Workshop Task Force in "Pre-Workshop Sessions". These sessions had two main intents: identifying and brainstorming possible ideas (as previously mentioned) to be a focus throughout the event, and gauging for our development-specific sessions at what level an LSC would receive the most benefit from (see "Track Programming" below).

Introduction: 2:00-3:15PM ET:

Our introduction focused on three main segments: initial steps and icebreakers, strength-specific development, and LSC-specific culture building.

We began with personal introductions and a brief icebreaker, explaining the day's sessions and events before asking attendees to share and explain an item of personal significance. We then progressed into strength-specific development, focused on identifying attendee's specific personal talents and abilities to best contribute to any group. In the weeks leading up to the Workshop, attendees were asked to create a Good & Co. profile, a software that asks personality and productivity questions before providing analytical information about team compatibility and personal capabilities. Athletes were then sorted by common traits (without being told what the trait was), discussed amongst themselves in breakout rooms with a Workshop leader to figure out what their common trait was, and were then asked to evaluate the benefits and weaknesses of this trait. Athletes were encouraged to consider how they could use such traits in their work within USA Swimming and all aspects of their lives. You can find their workspace for this discussion here:

<https://app.mural.co/t/virtualworkshop20206149/m/virtualworkshop20206149/1594344279375/f37469d89ec46ca90bbe1db69f8bb9e65561f816>

The Introduction then concluded with an LSC-specific section, wherein attendees were sorted into breakout rooms by LSC and were assigned a Workshop leader to discuss with. They then discussed, evaluating their individual strengths, weaknesses, and traits, what the most successful working paths forward might be, and how their LSC work could be aligned most productively with their individual characters. They were encouraged to build LSC cultures and environments with a heavy emphasis on this common plan. You can find their workspace for this discussion here:

<https://app.mural.co/t/virtualworkshop20206149/m/virtualworkshop20206149/1594344762471/fcb622403adb10a673353eaf8cc5247dfb27ab3a>

Professional Communications: 3:25-4:05PM ET:

This session focused on professional communication, with an emphasis on adjusting these skills as necessary for the virtual world (an increasingly common feature of these athletes' work). The content emphasized the continued need to evaluate tone, audience, and purpose when communication in any situation, and on adjusting these factors as needed to create effective communication paths. Specific emphasis was placed on how these factors can be translated to electronic communication and messages (texts & emails) and real-time communication (Zoom and in-person meetings). Real-life and engaging examples were used as much as possible; communication is generally taught in-person to Athlete Reps and we had to compensate for that loss of efficacy.

The session concluded with a hands-on activity; athletes were grouped into specific breakout rooms with a non-athlete leader and were sent based on their group an email from a specific individual about a similar situation, before being asked to respond accordingly. In our situation, we discussed a negative facility change just weeks before a championship meet, and sent emails in a variety of tones and backgrounds to challenge our attendees to create the most effective specific response. They were then provided with constructive feedback on their response.

Track Programming: 4:30-5:30PM ET:

Based on their Pre-Workshop Sessions, athletes were separated into two tracks: Track 1 for LSC cohorts with less experience or LSC development, and Track 2 for LSC cohorts with a more developed and extensive history of athlete representation. Track 1 focused primarily on building foundational skills for project development and execution, and Track 2 focused more on the fine-tuning and advanced portions of legislation and events.

Track 1: Athlete Representatives were guided through the foundations of project development, including the ideation and execution processes. Athletes serving on the Rules and Regulations Committee spoke about the basics of legislation and affiliated projects, and the AEC Programming & Events Chair spoke similarly about the process of creating and hosting an event-based project. Athletes were then broken out into breakout rooms, and encouraged to discuss with Workshop leaders their progress and future steps. To see the athletes' workspace, use this link:

<https://app.mural.co/t/virtualworkshop20206149/m/virtualworkshop20206149/1594342013969/0e47ad4243cb5f1785f2b6208b4d627d13de73d9>

Track 2: Athlete Representatives were given more advanced information regarding legislation and event development, also from the Rules & Regulations Committee Athletes and from the AEC Programming & Events Chair. The Track 2 session consisted of a substantial amount of work time, wherein LSC Reps were given breakout rooms to discuss their progress and could communicate with Workshop leaders as they pleased. This session was primarily focused on building more complex existing ideas into highly-functional final products. To see the athletes' workspace, use this link:

<https://app.mural.co/invitation/mural/virtualworkshop20206149/1594343829662?sender=szathletes0250&key=ab95641a-9ea4-452b-8659-eff55e56241a>

LSC Non-Athlete Leadership Discussion: 4:45-5:30PM ET:

All LSC General Chairs were invited and encouraged to attend this section of the workshop, and were also encouraged to invite other LSC non-athlete leaders as beneficial. Van Donkersgoed (WI) and Joe Gazzarato (MI) were guest speakers for this session as Athlete Reps who then went on to become LSC General Chairs. They spoke on their experiences in both roles and about the support and relationships which they have built with their LSC Athlete Representatives, before answering questions (along with Workshop leaders) from the LSC leaders about further including and supporting their LSC Athlete Representatives.

LSC Breakout Rooms: 5:30-6:00PM ET:

Athletes and non-athletes were brought together and separated into LSC-specific breakout rooms to discuss what each had learned in their respective workshops. Discussions were encouraged to be driven around the Athletes' projects and ideas, and specifically how the non-athletes could provide feedback and assistance as they worked forward towards executing

and implementing them. Workshop leaders floated between breakout rooms, and any breakout room could request assistance/discussion with a Workshop leader at any time.

Speaker Panel: 6:15-7:15PM ET:

Through connections offered by a couple of non-athlete and athlete leaders, our speaker panel ultimately consisted of Missy & Hayes Johnson and Katie Hoff, who spoke to the theme of “maximizing potential”. The panel focused greatly on leadership skills and transitioning swimming experiences to professional and personal pursuits, with each speaker discussing their experiences therein. The speakers then engaged in a Q&A with our attendees, discussing a wide range of topics and ideas. Nonathletes were also invited to attend this panel.

Conclusion: 7:15-7:30PM ET:

In our brief conclusion, athletes were asked to reflect on their experiences throughout the Workshop, and consider what their next steps would be in alignment with the skills they gained. We closed with a reminder of the importance of community and camaraderie, encouraging our Athlete Reps to support each other in all of their pursuits and to value above all else the friendships and relationships they develop throughout their work within the sport.

Feedback

Feedback from our attendees was overwhelmingly positive. Every single athlete submitting the anonymous end-of-Workshop feedback form indicated that they were engaged throughout the entire event and learned something new and important. Athletes rated their overall experience as being, on average, 4.88 on a scale of 1 to 5, with not a single attendee rating it lower than “4”. Each individual session received similarly positive feedback, with not a single attendee rating any session as being less than a “3” on scales of 1 to 5 for engagement and overall quality.

Some constructive feedback focused primarily on the timing of the Workshop, with many attendees suggesting that the given breaks be longer. Athletes generally felt that the introduction and the speaker section were the most engaging sessions, while the speaker section and the track programming were the most informative/helpful.

Summary & Future Opportunities

The Workshop was, as a whole, successful beyond our highest expectations - athletes maintained impressive levels of engagement, all discussion was high-quality, and each and every session seemed to be received as being quite helpful and enriching. As this was our first time ever running this event - and the first time any Zone has run any sort of similar workshop - we were expecting far more troubles, “dead space”, and difficulty than we ever experienced during our July 11 event. While only time will tell if our attendees are able to utilize their gained

skills and experiences to instill tangible benefits in their work towards their LSCs, we feel confident that they will have the opportunity and ability to do so.

Looking towards the future, we find that we are nearing a point wherein we are maximizing our ability given our current circumstances. While a virtual workshop did allow us to run the event with a shorter planning time, and ultimately allowed us to hold this event in the COVID world, the restrictions of this means of operations became quite clear. The overall efficacy of any of our curriculum was decreased by our inability to meet and work in-person, our ability to discuss communications was specifically limited by our inability to interact with in-person communications, and primarily, because we cannot ask for our athletes to sit on an over-extensive Zoom call, the workable time with which we had to go through content was much more compressed. While we can change and shift some content, and make some adjustments to time allotments, we have created a Workshop with substantial potential dependent on the opportunities it is given: we likely cannot grow it much more in a virtual setting.

As such, our next steps are going to primarily include identifying ways in which this can ultimately become an in-person event. Seeking funding specifically through the Zone budget would be ideal; however, we as a Zone Board have decided not to propose an increase at the 2020 Zone Meeting due to the ongoing financial situations many of our LSCs find themselves in. We are considering possibly identifying other opportunities for funding and growth, and while we have some creative solutions, we are going to be mostly dependent on the ability of groups other than the Southern Zone to provide funding if an in-person event is to occur in 2021 (because of the hold on a Southern Zone budget increase, we will not have adequate funding to host an event before 2022).

We believe strongly, especially after seeing the incredible success and efficacy of this pilot event, that these workshops and their curriculum may be a key way in which we can further benefit our athlete governance leaders and, accordingly, our sport as a whole. We are committed to finding ways in which this event can be grown and developed to enhance the opportunities our athletes are given to make change within their LSCs and USA Swimming, and look forward to the hopefully successful and growing future of the Southern Zone Athlete Workshop within the greater context of USA Swimming's operations.

For more information, please contact szathletes@gmail.com (account managed by Senior and Junior Athlete Representatives).





APPLICATION FOR SOUTHERN ZONE

AGE GROUP SWIMMING / SENIOR CHAMPIONSHIPS (select one)

The Ms Local Swimming Committee wishes to bid for the 2022 Southern Zone Age Group Swimming / Senior Championships (select one).

Wade Kijima (by ZAKBANA Aquatics, Inc) Chairman, Local Swimming Committee USA Swimming, Inc.

The organization that will be assigned the Championship is the:

NAME: Shockwave Aquatics Team ADDRESS: P.O. Box 3423 CITY: STATE: ZIP: Tupelo, Ms 38803 PHONE: (662) 401-7550

The organization President is:

NAME: Gene Mc Dade ADDRESS: P.O. Box 3423 CITY: STATE: ZIP: Tupelo, Ms. 38803 PHONE: (662) 321-3210

FACILITY INFORMATION

Please read and comply with the Southern Zone Meet Handbook and Article 103 - Facility Standards, USA Swimming Rules and Regulations. Please be certain you understand the requirements for hosting the meets.

If the organization is awarded these Championships, we propose to conduct the meet at the following facilities.

- 1. Name of Facility: Tupelo Aquatic Center
2. Name of Pool (if different):
3. Organization Administering Facility: City of Tupelo
4. Facility Administrator: Amy Kennedy
5. Address: 692 North Veterans Memorial Blvd. MAILING P.O. Box 3608 Tupelo, MS 38803

6. City: State: Zip: Tupelo, Ms. 38803

1. Phone: (662) 840-3768

2. Pool Street Address: 692 North Veterans Memorial Blvd

3. City: State: Zip: Tupelo, Ms. 38804

8. The pool is 1 years old. It opened for the first time on 11/23/2013 (date).

9. The pool is: X indoor _____ outdoor _____ indoor / outdoor

8. What is the depth of the pool? Start end: 7'5" Center: 7' Turn end: 4'6"

Are all lanes the same depth? no. If not, explain: _____

12'4" deep @ northeast side of pool (Dive envelope extended across 4 lanes of pool width)

Please sketch a profile of the pool bottom with the depths marked:

9. There are 8 lanes for racing. Each lane is 9' wide.

10. Does the pool have a water heater? yes A water cooling system? no

11. Can you guarantee that the water will be the correct temperature range for competition? yes with no current yes.

12. What is the candlepower lighting three feet above the water with existing lights? 72.71 ft Candlepower at finishing and turning end? 56 ft

13. Brand name of lane dividers Competitor 6"

14. What type of gutter system is installed? Myrtha Classic Fitter

15. Warm-Up Pool(s): (min of 6 lanes)

Length 25 yds Width 30 ft Depth at Shallow end: 3'6" to 4'6"

Number of lanes 5 Width of lanes 6'

Starting Platforms no Backstroke Ledges only in comp pool

Indoor/Outdoor pool indoor

Distance from competitive pool 19'

Will lane dividers be provided? yes What type? competitor 6"

16. Starting platform information:

A. Size of platform surface Length 32" Width 24"

B. If slanted, the degree of slant 10°

C. Height above water surface 29.5"

D. Are all surfaces non-skid yes

17. Timing system trade name and model of automatic timing system: _____

Colorado Timing System 6

A. Is it installed or rented? UNINSTALLED

B. Name of touch pads Colorado time system 78" Aquagrips

C. Name of back up system Colorado Timing System

D. Where is it located? MEET MANAGEMENT office -

E. Is a readout scoreboard installed? yes If not will you rent one? _____

How many lines? 21

18. Do you have, or will you have a sound starting device under each lane? yes

19. Computerization: What computer system and meet management program will be used for the meet? Hy-tek

20. Scoreboard: Will you have a team scoreboard for 1 - 15 places? prelims yes
What type? Colorado

21. What are the deck measurements? Left side 19'4" Right side 12'
Turning end 16'6" Behind start 14'4"

22. Total seating capacity in pool area 971+500 (min of 1200 seating)
(min deck space 550-700)

Right side of pool 500 Left side of pool upper level (971)

Starting end --- Turning end ---

Comments: _____

23. Resting Area:

Is it convenient? yes Is it shaded? yes How large? 20x30' air conditioned event tent

Indoor/Outdoor? outdoor How far from the rest area to the pool? 15 yards

24. Locker Facilities: (20 swimmers + equipment min)

Women: # lockers 240 # showers 6 # toilets 5

Men: # lockers 108 # showers 6 # toilets 5

25. P.A. System:

In pool area yes In warm-up pool area yes In locker rooms yes In rest area yes

Are acoustics acceptable if indoors? yes

Are speakers adequate if outdoors? yes

26. Will the facilities be available to only swimmers on a full-time basis beginning one day before the meet? yes

27. Is a Certification of Pool Length Application on file at the United States Swimming National Headquarters? yes

28. Do you have any policies that would restrict USA sponsorship obligations? NO

29. Per USA Swimming Rules and Regulations NO NOISE MAKERS WILL BE ALLOWED AT MEET.

30. Will meet marshals/Invigilators be available throughout the meet? yes

1. Hotel Headquarters: a list is provided

Name: Address: City: State: Zip: _____

Phone:(____) _____

Manager's Name: _____

Number of rooms: _____ Distance from hotel to pool: _____

Room rates: Single _____

Double: _____

Quad: _____

Describe facilities, including the restaurants and hours of operation: _____

2. Other Hotels:

Please attach a list of other hotels with the following information: list ATTACHED

Name: Number of rooms: 600 plus rooms

Room rates: Single _____

Double: _____

Quad: _____

Driving time to pool: all less than 5 miles to pool

Contact Name: Address: _____

Phone: (_____) _____

3. Please indicate the number of restaurants in each category:

Fast food: 1-5 miles 50 6-10 miles _____ 11-20 miles _____

Inexpensive: 1-5 miles 60 6-10 miles _____ 11-20 miles _____

Moderate: 1-5 miles 20 6-10 miles _____ 11-20 miles _____

} 130 plus total restaurants

4. Transportation To And From The City: yes

Airlines serving the city: contour (Tupelo - Nashville)

Memphis International Airport - 90 miles from Tupelo

Distance from airport to the pool: 5 miles Will there be free transportation from the hotels to the pool? NO Schedule? N/A

How many rental vans are available at the airport? _____

Car rental companies serving the city: Budget, Hertz, Enterprise, Avis, Kia, Moby

Is there a traffic problem getting to the pool from housing? NO

If so, explain: _____

Hotel	General Manager	Email	Director of Sales
All American Coliseum	Jay		
Americas Best Value Inn	Jay Patel	abvietupelo@yahoo.com	
Baymont Inn	Dimple Patel	deltahospitalityllc@gmail.com	
Best Western Inn & Suites	Alicia O'Rear	gm@bwtupelo.com	Stephanie West
Candlewood Suites	Porsha Holiday	gm@cwtupelo.com	Stephanie West
Clarion Inn	Milan Patel	gm.ms247@choicehotels.com	
Comfort Inn	Carolyn Moss	gm@comfortinntupelo.com	Stephanie West
Commodore Motel			
Courtyard by Marriott	Kim Crump	kcrump@zmchotels.com	
Days Inn		DaysInn05940@gmail.com	
Econolodge	Dee Patel	gm.ms271@choicehotels.com	
Economy Inn	Kedu Patel		
Fairfield Inn & Suites	Gwendolyn Hudson	ghudson@cmzhotels.com	Courtney Philpot
Gumtree Inn	Jan Rankin	kcrump@zmchotels.com	
Hampton Inn & Suites	Stephanie Browning	stephanie.browning2@hilton.com	
Hilton Garden Inn			
Holiday Inn & Suites	Scott Kent	gm@hitupelo.com	Demetra Sherer
Holiday Inn Express	Leslie Pender	gm@hiexpressupelo.com	Stephanie West
La Quinta	Mike Patel	lq6380gm@laquinta.com	Christy Cook
Motel 6	Kishan Patel	motel64536@gmail.com	Brandee Boyd
Quality Inn	Vic Patel	gm.ms408@choicehotels.com	
Red Roof Inn	Chan Patel	i0431@redroof.com	
Rodeway Inn	Demeka McKinney	gm@comfortinntupelo.com	<u>Stephanie West</u>
Scottish Inn	Jay Patel		
Summit Center			
Super 8 Motel	Vinod Patel	vinodpatel766@yahoo.com	
Town House Motel	Champak Kalyanji	townhousemotellic@yahoo.com	
Travelers Motel			
Wingate by Wyndham	Cheryl Foster	cheryl@tupelowingateinn.com	Cheryl Foster
Fusion Hospitality	Assoc. Director Sales	ranae@fusion-hospitality.com	Ranae Caldwell
	<i>Comfort Inn & Suites</i>	<i>Comfortsuitestupelo@gmail.com</i>	<i>110⁰⁰ plus tax for Dol orKine</i>
	<i>Dimple Patel</i>		

→ 129⁰⁰ for 2021 → 139⁰⁰ for 2022

129⁰⁰ for 2021 139⁰⁰ for 2022

Email	Address	City	State	Zip	Phone	Beds
stephanie@fusion-hospitality.com	767 East Main Street	Tupelo	MS	38804	662.844.5610	71
stephanie@fusion-hospitality.com	4701 Leeb Drive	Tupelo	MS	38804	662.269.6220	51
stephanie@fusion-hospitality.com	625 Spicer Drive	Tupelo	MS	38804	662.844.7660	60
stephanie@fusion-hospitality.com	3158 North Gloster	Tupelo	MS	38804	662.847.0300	80
stephanie@fusion-hospitality.com	979 North Gloster St.	Tupelo	MS	38804	662.553.4649	79
stephanie@fusion-hospitality.com	852 N. Gloster	Tupelo	MS	38802	662.844.4343	65
stephanie@fusion-hospitality.com	1532 McCullough Blvd.	Tupelo	MS	38804	662.840.0340	58
stephanie@fusion-hospitality.com	1800 East Main	Tupelo	MS	38804	662.842.9074	
stephanie@fusion-hospitality.com	1320 North Gloster	Tupelo	MS	38804	662.841.9960	93
stephanie@fusion-hospitality.com	1015 North Gloster	Tupelo	MS	38804	662.842.0088	40
stephanie@fusion-hospitality.com	879 Mississippi Drive	Tupelo	MS	38804	662.840.2380	60
stephanie@fusion-hospitality.com	708 North Gloster	Tupelo	MS	38804	662.842.1213	25
cpilipot@zmnchotels.com	3070 Tom Watson Dr.	Saltillo	MS	38866	662.680.6798	87
cpilipot@zmnchotels.com	101 Thompson Street	Tupelo	MS	38801	662.841.5083	
cpilipot@zmnchotels.com	1116 Carter Cove	Tupelo	MS	38804	662.821.0317	88
cpilipot@zmnchotels.com	363 East Main	Tupelo	MS	38804	662.718.5500	158
dscherer@peachtreehotelgroup.com	923 North Gloster	Tupelo	MS	38804	662.269.0096	121
stephanie@fusion-hospitality.com	1612 McClure Cove	Tupelo	MS	38804	662.620.8184	101
christy@fusion-hospitality.com	1013 North Gloster	Tupelo	MS	38804	662.847.8000	70
lq6380agm@laquinta.com	1500 McCullough Blvd.	Tupelo	MS	38804	662.844.1904	97
lq6380agm@laquinta.com	1190 North Gloster	Tupelo	MS	38804	662.842.5100	83
lq6380agm@laquinta.com	1516 McCullough Blvd.	Tupelo	MS	38804	662.840.8300	96
stephanie@fusion-hospitality.com	852 North Gloster	Tupelo	MS	38804	662.844.4464	49
stephanie@fusion-hospitality.com	401 North Gloster	Tupelo	MS	38804	662.842.1961	45
stephanie@fusion-hospitality.com	852 N. Gloster	Tupelo	MS	38802	662.842.1561	
stephanie@fusion-hospitality.com	3898 McCullough	Belden	MS	38826	662.842.0448	49
stephanie@fusion-hospitality.com	931 South Gloster	Tupelo	MS	38801	662.842.5411	36
stephanie@fusion-hospitality.com	915 North Gloster	Tupelo	MS	38804	662.844.2221	40
cheryl@tupelowingateinn.com	186 Stonecreek Blvd.	Tupelo	MS	38804	662.680.8887	

PROPOSAL FOR Southern Zone Swim

Event Date: **July 2022**

Holiday Inn Express & Suites – Breakfast Included

Number of Rooms	Room Type	Price	Nights
	Traditional Double Queen	\$129 per night + tax	
	Traditional Single King	\$129 per night + tax	

Holiday Inn & Suites

Number of Rooms	Room Type	Price	Nights
	Traditional Double Queen	\$134 per night + tax	
	Traditional Single King	\$134 per night + tax	

Best Western Plus - Breakfast Included

Number of Rooms	Room Type	Price	Nights
	Traditional Double Queen	\$124 per night + tax	
	Traditional Single King	\$124 per night + tax	

Comfort Inn - Breakfast Included

Number of Rooms	Room Type	Price	Nights
	Traditional Double Queen	\$104 per night + tax	
	Traditional Single King	\$104 per night + tax	

Proposal Sent: 8/3/2020

Proposal Expires: 10/3/2020

Proposal prepared by Christy Cook, Director of Sales
Holiday Inn Express & Suites
1612 McClure Cove, Tupelo, MS 38804
Direct 662-871-8304 / Hotel 662-620-8184
christy@fusion-hospitality.com



APPLICATION FOR SOUTHERN ZONE

AGE GROUP SWIMMING / SENIOR CHAMPIONSHIPS

(select one)

The NT Local Swimming Committee wishes to bid for the 2022 Southern Zone Age Group Swimming Senior Championship (select one).

Suzanne Dangelmaier, General Chair NTSI

Chairman, Local Swimming Committee USA Swimming, Inc.

The organization that will be assigned the Championship is the:

NAME: Arlington ISD Aquatic Club (AAC)

ADDRESS: 1001 E Division St

CITY: _STATE: ZIP: Arlington, TX 76011

PHONE: (214) 793-4773

The organization President is:

NAME: Suzanne Dangelmaier

ADDRESS: 1001 E Division St

CITY: STATE: ZIP: Arlington, TX 76011

PHONE: (214) 793-4773

FACILITY INFORMATION

Please read and comply with the **Southern Zone Meet Handbook** and Article 103 - Facility Standards, USA Swimming Rules and Regulations. Please be certain you understand the requirements for hosting the meets.

If the organization is awarded these Championships, we propose to conduct the meet at the following facilities.

1. Name of Facility: Arlington ISD Natatorium

2. Name of Pool (if different): _____

3. Organization Administering Facility: Arlington ISD

4. Facility Administrator: Suzanne Dangelmaier

5. Address: 1001 E Division St

6. City: State: Zip: Arlington, TX 76011

1. Phone: (214) 793-4773

2. Pool Street Address: 1001 E Division St

3. City: State: Zip: Arlington, TX 76011

8. The pool is 0 years old. It opened for the first time on Sept 2020 (date).

9. The pool is: indoor _____ outdoor _____ indoor / outdoor

8. What is the depth of the pool? Start end: 4.9m Center: 2.0m Turn end: 2.0m

Are all lanes the same depth? yes. If not, explain: _____

Please sketch a profile of the pool bottom with the depths marked:

9. There are 8 lanes for racing. Each lane is 8' wide.

10. Does the pool have a water heater? yes A water cooling system? no

11. Can you guarantee that the water will be the correct temperature range for competition? yes with no current yes.

12. What is the candlepower lighting three feet above the water with existing lights? _____ Candlepower at finishing and turning end? _____

13. Brand name of lane dividers AntiWave 6" Forerunner

14. What type of gutter system is installed? Myrtha

15. Warm-Up Pool(s): (min of 6 lanes)

Length 25yd Width 8' Depth at Shallow end: 4' continuous

Number of lanes 4 Width of lanes 8'

Starting Platforms no Backstroke Ledges no

Indoor/Outdoor pool Indoor

Distance from competitive pool 20m

Will lane dividers be provided? yes What type? AntiWave 6" Forerunner

16. Starting platform information:

A. Size of platform surface Length 32 Width 24.25

B. If slanted, the degree of slant 10

C. Height above water surface 25"

D. Are all surfaces non-skid yes

17. Timing system trade name and model of automatic timing system: _____

Colorado Timing System 7

A. Is it installed or rented? installed

B. Name of touch pads Colorado Timing

C. Name of back up system multiple systems in inventory

D. Where is it located? on site

E. Is a readout scoreboard installed? yes If not will you rent one? _____

How many lines? 8x2 2 - 20' LED Video/Scoreboards

18. Do you have, or will you have a sound starting device under each lane? yes

19. Computerization: What computer system and meet management program will be used for the meet? Hy-Tek MM

20. Scoreboard: Will you have a team scoreboard for 1 - 15 places? yes

What type? Colorado Timing

21. What are the deck measurements? Left side 11' Right side 20'

Turning end 9' Behind start 17'

22. Total seating capacity in pool area 1200 (min of 1200 seating)

(min deck space 550-700)

Right side of pool 450 Left side of pool 300

Starting end n/a Turning end 100

Comments: additional seating space in adjacent warm-up pool area

23. Resting Area:

Is it convenient? Y Is it shaded? Y How large? attached sports arena seats 1200, plus floor space

Indoor/Outdoor? Indoor How far from the rest area to the pool? 50'

24. Locker Facilities: (20 swimmers + equipment min)

Women: # lockers _____ # showers 8 # toilets 13

Men: # lockers _____ # showers 8 # toilets 7

Separate restrooms for coaches and officials

25. P.A. System:

In pool area yes In warm-up pool area yes In locker rooms _____ In rest area Yes

Are acoustics acceptable if indoors? yes

Are speakers adequate if outdoors? _____

26. Will the facilities be available to only swimmers on a full-time

basis beginning one day before the meet? yes

27. Is a Certification of Pool Length Application on file at the United

States Swimming National Headquarters? to be submitted upon completion of construction

28. Do you have any policies that would restrict USA sponsorship

obligations? No

29. Per USA Swimming Rules and Regulations NO NOISE MAKERS WILL BE ALLOWED AT MEET.

30. Will meet marshals/Invigilators be available throughout the meet? yes

1. Hotel Headquarters:

Name: Address: City: State: Zip: See attached

Phone:(____) _____

Manager's Name: _____

Number of rooms:_____ Distance from hotel to pool: _____

Room rates: Single _____

Double: _____

Quad: _____

Describe facilities, including the restaurants and hours of operation: _____

2. Other Hotels:

Please attach a list of other hotels with the following information:

Name: Number of rooms: _____

Room rates: Single _____

Double: _____

Quad: _____

Driving time to pool: _____

Contact Name: Address: _____

Phone: (____) _____

3. Please indicate the number of restaurants in each category:

Fast food: 1-5 miles 50+ 6-10 miles 100+ 11-20 miles _____

Inexpensive: 1-5 miles 25+ 6-10 miles 100+ 11-20 miles _____

Moderate: 1-5 miles 20+ 6-10 miles 50+ 11-20 miles _____

4. Transportation To And From The City: _____

Airlines serving the city: All major airlines at DFW; Southwest and AA at Dallas Love Field

Distance from airport to the pool: 14.6mi Will there be free transportation from the hotels to the pool? no Schedule? _____

How many rental vans are available at the airport? unlimited

Car rental companies serving the city: all major companies

Is there a traffic problem getting to the pool from housing? no

If so, explain: _____



Prepared On: 08/12/2020
 Prepared By: Kayla Gostnell

QUERY RESULTS - 26 RECORDS RETURNED

Account Name	Rooms Total
817 Hotel, by Days Inn by Wyndham	93
Aloft Arlington Entertainment District	136
Baymont Inn & Suites by Wyndham	95
Candlewood Suites Arlington	125
Comfort Suites Arlington	108
Courtyard by Marriott Arlington	147
Days Inn by Wyndham	104
Extended Stay America	137
Fairfield Inn & Suites by Marriott	101
Four Points By Sheraton	102
Hawthorn Suites by Wyndham Arlington	129
Hilton Arlington	308
Hilton Garden Inn	132
Holiday Inn Arlington NE - Rangers Ballpark	147
Homewood Suites by Hilton	89
Howard Johnson by Wyndham	98
Hyatt Place Arlington	127
InTown Suites	133
La Quinta Inn & Suites Six Flags Drive	178
Live! By Loews	300
Ranger Inn & Suites	40
Red Roof Inn	100
Sheraton Arlington Hotel	311
Sleep Inn Arlington Near Six Flags	126
SpringHill Suites by Marriott	121
TownePlace Suites by Marriott	94



Prepared On: 08/12/2020
Prepared By: Kayla Gostnell

QUERY RESULTS - 19 RECORDS RETURNED

Account Name	Status	Boxed Meals	Group Menu's	Meeting Room: Space Type	Meeting Room Capacity	Offsite Catering	Takeout - Catering
J. Gilligan's Bar & Grill	Partner	No	No	Private	100	Yes	Yes
VIP Sports Bar & Grill	Partner	No	No	Flexible	98	Yes	Yes
VIP Sports Bar & Grill	Partner	No	No	Private	98	Yes	Yes
Babe's Chicken Dinner House	Partner	Yes	No	N/A		Yes	Yes
BoomerJack's Bar & Grill	Partner	Yes	No	Semi Private	65	Yes	Yes
Piccolo Mondo Italian Restaurant	Partner	No	Yes	Private	40	Yes	No
Prince Lebanese Grill	Partner	Yes	Yes	N/A	60	Yes	Yes
Buffalo Wings & Rings	Partner	No	Yes	N/A	0	Yes	Yes
Social House	Partner	No	Yes	Semi Private	100	Yes	No
Boston's Restaurant & Sports Bar	Prospect	Yes	No	Semi Private	80	Yes	Yes
Piranha Killer Sushi North	Prospect	Yes	Yes	N/A	0	Yes	Yes
Buffalo Wild Wings Grill & Bar	Prospect	No	No			No	No
Panera Bread	Prospect	Yes	No			Yes	Yes
Greasemonkey Burgers	Prospect	No	No			Yes	Yes
Lupe's Tex Mex Grill	Prospect	No	No			Yes	Yes
BFF Asian Grill & Sports Bar	Prospect	No	No			Yes	Yes
Vila Brazil Steak House	Prospect	No	Yes	Private	80	Yes	No
The Rock Wood Fired Kitchen	Prospect	No	Yes	Semi Private	100	No	Yes
Mercury Chop House	Prospect	No	No	Private	22	No	Yes



APPLICATION FOR SOUTHERN ZONE

AGE GROUP SWIMMING / SENIOR CHAMPIONSHIPS (select one)

The Ms Local Swimming Committee wishes to bid for the 2022 Southern Zone Age Group Swimming / Senior Championships (select one).

Wade Kojima (by BARBARA Annette, sec) Chairman, Local Swimming Committee USA Swimming, Inc.

The organization that will be assigned the Championship is the:

NAME: Shockwave Aquatics Team

ADDRESS: P.O. Box 3423

CITY: STATE: ZIP: Tupelo, Ms 38803

PHONE: (662) 401-7550

The organization President is:

NAME: Gene Mc Dade

ADDRESS: P.O. Box 3423

CITY: STATE: ZIP: Tupelo, Ms. 38803

PHONE: (662) 321-3210

FACILITY INFORMATION

Please read and comply with the Southern Zone Meet Handbook and Article 103 - Facility Standards, USA Swimming Rules and Regulations. Please be certain you understand the requirements for hosting the meets.

If the organization is awarded these Championships, we propose to conduct the meet at the following facilities.

1. Name of Facility: Tupelo Aquatic Center

2. Name of Pool (if different):

3. Organization Administering Facility: City of Tupelo

4. Facility Administrator: Amy Kennedy

5. Address: 692 North Veterans Memorial Blvd.

MAILING P.O. Box 3608 Tupelo, MS 38803

6. City: State: Zip: Tupelo, Ms. 38803

1. Phone: (662) 840-3768

2. Pool Street Address: 692 North Veterans Memorial Blvd

3. City: State: Zip: Tupelo, Ms. 38804

8. The pool is 1 years old. It opened for the first time on 11/23/2013 (date).

9. The pool is: X indoor _____ outdoor _____ indoor / outdoor

8. What is the depth of the pool? Start end: 7'5" Center: 7' Turn end: 4'6"

Are all lanes the same depth? no. If not, explain: 12'4" deep @ northeast side of pool (Dive envelope extended across 4 lanes of pool width)

Please sketch a profile of the pool bottom with the depths marked:

9. There are 8 lanes for racing. Each lane is 9' wide.

10. Does the pool have a water heater? yes A water cooling system? no

11. Can you guarantee that the water will be the correct temperature range for competition? yes with no current yes.

12. What is the candlepower lighting three feet above the water with existing lights? 72.77 ft Candlepower at finishing and turning end? 56 ft

13. Brand name of lane dividers Competitor 6"

14. What type of gutter system is installed? Myrtha Classic Fitter

15. Warm-Up Pool(s): (min of 6 lanes)

Length 25 yds Width 30 ft Depth at Shallow end: 3'6" to 4'6"

Number of lanes 5 Width of lanes 6'

Starting Platforms no Backstroke Ledges only in comp pool

Indoor/Outdoor pool indoor

Distance from competitive pool 19'

Will lane dividers be provided? yes What type? competitor 6"

16. Starting platform information:

A. Size of platform surface Length 32" Width 24"

B. If slanted, the degree of slant 10°

C. Height above water surface 29.5"

D. Are all surfaces non-skid yes

17. Timing system trade name and model of automatic timing system: _____

Colorado Timing System 6

A. Is it installed or rented? UNINSTALLED

B. Name of touch pads Colorado time system 78" Aquagrips

C. Name of back up system Colorado Timing System

D. Where is it located? MEET MANAGEMENT office -

E. Is a readout scoreboard installed? yes If not will you rent one? _____

How many lines? 21

18. Do you have, or will you have a sound starting device under each lane? yes

19. Computerization: What computer system and meet management program will be used for the meet? Hy-tek

20. Scoreboard: Will you have a team scoreboard for 1 - 15 places? prelims yes
What type? Colorado

21. What are the deck measurements? Left side 19'4" Right side 12'
Turning end 16'6" Behind start 14'4"

22. Total seating capacity in pool area 971+500 (min of 1200 seating)
(min deck space 550-700)

Right side of pool 500 Left side of pool upper level (971)

Starting end -0- Turning end -0-

Comments: _____

23. Resting Area:

Is it convenient? yes Is it shaded? yes How large? 20x30' air conditioned event tent

Indoor/Outdoor? outdoor How far from the rest area to the pool? 15 yards

24. Locker Facilities: (20 swimmers + equipment min)

Women: # lockers 240 # showers 6 # toilets 5

Men: # lockers 108 # showers 6 # toilets 5

25. P.A. System:

In pool area yes In warm-up pool area yes In locker rooms yes In rest area yes

Are acoustics acceptable if indoors? yes

Are speakers adequate if outdoors? yes

26. Will the facilities be available to only swimmers on a full-time basis beginning one day before the meet? yes

27. Is a Certification of Pool Length Application on file at the United States Swimming National Headquarters? yes

28. Do you have any policies that would restrict USA sponsorship obligations? NO

29. Per USA Swimming Rules and Regulations NO NOISE MAKERS WILL BE ALLOWED AT MEET.

30. Will meet marshals/Invigilators be available throughout the meet? yes

1. Hotel Headquarters: a list is provided

Name: Address: City: State: Zip: _____

Phone:(____) _____

Manager's Name: _____

Number of rooms: _____ Distance from hotel to pool: _____

Room rates: Single _____

Double: _____

Quad: _____

Describe facilities, including the restaurants and hours of operation: _____

2. Other Hotels:

Please attach a list of other hotels with the following information: list ATTACHED

Name: Number of rooms: 600 plus rooms

Room rates: Single _____

Double: _____

Quad: _____

Driving time to pool: all less than 5 miles to pool

Contact Name: Address: _____

Phone: (_____) _____

3. Please indicate the number of restaurants in each category:

Fast food: 1-5 miles 50 6-10 miles _____ 11-20 miles _____

Inexpensive: 1-5 miles 60 6-10 miles _____ 11-20 miles _____

Moderate: 1-5 miles 20 6-10 miles _____ 11-20 miles _____

} 130 plus total restaurants

4. Transportation To And From The City: yes

Airlines serving the city: contour (Tupelo - Nashville)

Memphis International Airport - 90 miles from Tupelo

Distance from airport to the pool: 5 miles Will there be free transportation from the hotels to the pool? NO Schedule? N/A

How many rental vans are available at the airport? _____

Car rental companies serving the city: Budget, Hertz, Enterprise, Avis, Kia, Moby

Is there a traffic problem getting to the pool from housing? NO

If so, explain: _____

Hotel	General Manager	Email	Director of Sales
All American Coliseum	Jay		
Americas Best Value Inn	Jay Patel	abvietupelo@yahoo.com	
Baymont Inn	Dimple Patel	deltahospitalityllc@gmail.com	
Best Western Inn & Suites	Alicia O'Rear	gm@bwtupelo.com	Stephanie West
Candlewood Suites	Porsha Holiday	gm@cwtupelo.com	Stephanie West
Clarion Inn	Milani Patel	gm.ms247@choicehotels.com	
Comfort Inn	Carolyn Moss	gm@comfortinntupelo.com	Stephanie West
Commodore Motel			
Courtyard by Marriott	Kim Crump	kcrump@zmchotels.com	
Days Inn		Daysinn05940@gmail.com	
Econolodge	Dee Patel	gm.ms271@choicehotels.com	
Economy Inn	Kedu Patel		
Fairfield Inn & Suites	Gwendolyn Hudson	ghudson@cmzhotels.com	Courtney Philpot
Gumtree Inn	Jan Rankin	kcrump@zmchotels.com	
Hampton Inn & Suites	Stephanie Browning	stephanie.browning2@hilton.com	
Hilton Garden Inn			
Holiday Inn & Suites	Scott Kent	gm@hitupelo.com	Demetra Sherer
Holiday Inn Express	Leslie Pender	gm@hiexpresstupelo.com	Stephanie West
La Quinta	Mike Patel	lq6380gm@laquinta.com	Christy Cook
Motel 6	Kishan Patel	motel64536@gmail.com	Brandee Boyd
Quality Inn	Vic Patel	gm.ms408@choicehotels.com	
Red Roof Inn	Chan Patel	i0431@redroof.com	
Rodeway Inn	Demeka McKinney	gm@comfortinntupelo.com	Stephanie West
Scottish Inn	Jay Patel		
Summit Center			
Super 8 Motel	Vinod Patel	vinodpatel766@yahoo.com	
Town House Motel	Champak Kalyanji	townhousemotelllc@yahoo.com	
Travelers Motel			
Wingate by Wyndham	Cheryl Foster	cheryl@tupelowingateinn.com	Cheryl Foster
Fusion Hospitality	Assoc. Director Sales	ranae@fusion-hospitality.com	Ranae Caldwell
Comfort Inn & Suites	Dimple Patel	comfortsuitestupelo@gmail.com	110 ⁰⁰ plus th for DBL of King

→ 129⁰⁰ for 2021 139⁰⁰ for 2022

129⁰⁰ for 2021 139⁰⁰ for 2022

Email	Address	City	State	Zip	Phone	Beds
stephanie@fusion-hospitality.com	767 East Main Street	Tupelo	MS	38804	662.844.5610	71
stephanie@fusion-hospitality.com	4701 Leeb Drive	Tupelo	MS	38804	662.269.6220	51
stephanie@fusion-hospitality.com	625 Spicer Drive	Tupelo	MS	38804	662.844.7660	60
stephanie@fusion-hospitality.com	3158 North Gloster	Tupelo	MS	38804	662.847.0300	80
stephanie@fusion-hospitality.com	979 North Gloster St.	Tupelo	MS	38804	662.553.4649	79
stephanie@fusion-hospitality.com	852 N. Gloster	Tupelo	MS	38802	662.844.4343	65
stephanie@fusion-hospitality.com	1532 McCullough Blvd.	Tupelo	MS	38804	662.840.0340	58
stephanie@fusion-hospitality.com	1800 East Main	Tupelo	MS	38804	662.842.9074	
stephanie@fusion-hospitality.com	1320 North Gloster	Tupelo	MS	38804	662.841.9960	93
stephanie@fusion-hospitality.com	1015 North Gloster	Tupelo	MS	38804	662.842.0088	40
stephanie@fusion-hospitality.com	879 Mississippi Drive	Tupelo	MS	38804	662.840.2380	60
stephanie@fusion-hospitality.com	708 North Gloster	Tupelo	MS	38804	662.842.1213	25
stephanie@fusion-hospitality.com	3070 Tom Watson Dr.	Saltillo	MS	38866	662.680.6798	87
cpilipot@zmchotels.com	101 Thompson Street	Tupelo	MS	38801	662.841.5083	
cpilipot@zmchotels.com	1116 Carter Cove	Tupelo	MS	38804	662.821.0317	88
cpilipot@zmchotels.com	363 East Main	Tupelo	MS	38804	662.718.5500	158
cpilipot@zmchotels.com	923 North Gloster	Tupelo	MS	38804	662.269.0096	121
cpilipot@zmchotels.com	1612 McClure Cove	Tupelo	MS	38804	662.620.8184	101
cpilipot@zmchotels.com	1013 North Gloster	Tupelo	MS	38804	662.847.8000	70
cpilipot@zmchotels.com	1500 McCullough Blvd.	Tupelo	MS	38804	662.844.1904	97
cpilipot@zmchotels.com	1190 North Gloster	Tupelo	MS	38804	662.842.5100	83
cpilipot@zmchotels.com	1516 McCullough Blvd.	Tupelo	MS	38804	662.840.8300	96
cpilipot@zmchotels.com	852 North Gloster	Tupelo	MS	38804	662.844.4464	49
cpilipot@zmchotels.com	401 North Gloster	Tupelo	MS	38804	662.842.1961	45
cpilipot@zmchotels.com	852 N. Gloster	Tupelo	MS	38802	662.842.1561	
cpilipot@zmchotels.com	3898 McCullough	Belden	MS	38826	662.842.0448	49
cpilipot@zmchotels.com	931 South Gloster	Tupelo	MS	38801	662.842.5411	36
cpilipot@zmchotels.com	915 North Gloster	Tupelo	MS	38804	662.844.2221	40
cpilipot@zmchotels.com	186 Stonecreek Blvd.	Tupelo	MS	38804	662.680.8887	

PROPOSAL FOR Southern Zone Swim

Event Date: **July 2022**

Holiday Inn Express & Suites – Breakfast Included

Number of Rooms	Room Type	Price	Nights
	Traditional Double Queen	\$129 per night + tax	
	Traditional Single King	\$129 per night + tax	

Holiday Inn & Suites

Number of Rooms	Room Type	Price	Nights
	Traditional Double Queen	\$134 per night + tax	
	Traditional Single King	\$134 per night + tax	

Best Western Plus - Breakfast Included

Number of Rooms	Room Type	Price	Nights
	Traditional Double Queen	\$124 per night + tax	
	Traditional Single King	\$124 per night + tax	

Comfort Inn - Breakfast Included

Number of Rooms	Room Type	Price	Nights
	Traditional Double Queen	\$104 per night + tax	
	Traditional Single King	\$104 per night + tax	

Proposal Sent: 8/3/2020

Proposal Expires: 10/3/2020

Proposal prepared by Christy Cook, Director of Sales
Holiday Inn Express & Suites
1612 McClure Cove, Tupelo, MS 38804
Direct 662-871-8304 / Hotel 662-620-8184
christy@fusion-hospitality.com



APPLICATION FOR SOUTHERN ZONE

AGE GROUP SWIMMING / SENIOR CHAMPIONSHIPS
(select one)

The NT Local Swimming Committee wishes to bid for the 2022 Southern Zone Age Group Swimming Senior Championship (select one).

Suzanne Dangelmaier, General Chair NTSI

Chairman, Local Swimming Committee USA Swimming, Inc.

The organization that will be assigned the Championship is the:

NAME: Arlington ISD Aquatic Club (AAC)

ADDRESS: 1001 E Division St

CITY: _STATE: ZIP: Arlington, TX 76011

PHONE: (214) 793-4773

The organization President is:

NAME: Suzanne Dangelmaier

ADDRESS: 1001 E Division St

CITY: STATE: ZIP: Arlington, TX 76011

PHONE: (214) 793-4773

FACILITY INFORMATION

Please read and comply with the **Southern Zone Meet Handbook** and Article 103 - Facility Standards, USA Swimming Rules and Regulations. Please be certain you understand the requirements for hosting the meets.

If the organization is awarded these Championships, we propose to conduct the meet at the following facilities.

1. Name of Facility: Arlington ISD Natatorium

2. Name of Pool (if different): _____

3. Organization Administering Facility: Arlington ISD

4. Facility Administrator: Suzanne Dangelmaier

5. Address: 1001 E Division St

6. City: State: Zip: Arlington, TX 76011

1. Phone: (214) 793-4773

2. Pool Street Address: 1001 E Division St

3. City: State: Zip: Arlington, TX 76011

8. The pool is 0 years old. It opened for the first time on Sept 2020 (date).

9. The pool is: indoor _____ outdoor _____ indoor / outdoor

8. What is the depth of the pool? Start end: 4.9m Center: 2.0m Turn end: 2.0m

Are all lanes the same depth? yes. If not, explain: _____

Please sketch a profile of the pool bottom with the depths marked:

9. There are 8 lanes for racing. Each lane is 8' wide.

10. Does the pool have a water heater? yes A water cooling system? no

11. Can you guarantee that the water will be the correct temperature range for competition? yes with no current yes.

12. What is the candlepower lighting three feet above the water with existing lights? _____ Candlepower at finishing and turning end? _____

13. Brand name of lane dividers AntiWave 6" Forerunner

14. What type of gutter system is installed? Myrtha

15. Warm-Up Pool(s): (min of 6 lanes)

Length 25yd Width 8' Depth at Shallow end: 4' continuous

Number of lanes 4 Width of lanes 8'

Starting Platforms no Backstroke Ledges no

Indoor/Outdoor pool Indoor

Distance from competitive pool 20m

Will lane dividers be provided? yes What type? AntiWave 6" Forerunner

16. Starting platform information:

A. Size of platform surface Length 32 Width 24.25

B. If slanted, the degree of slant 10

C. Height above water surface 25"

D. Are all surfaces non-skid yes

17. Timing system trade name and model of automatic timing system: _____

Colorado Timing System 7

A. Is it installed or rented? installed

B. Name of touch pads Colorado Timing

C. Name of back up system multiple systems in inventory

D. Where is it located? on site

E. Is a readout scoreboard installed? yes If not will you rent one? _____

How many lines? 8x2 2 - 20' LED Video/Scoreboards

18. Do you have, or will you have a sound starting device under each lane? yes

19. Computerization: What computer system and meet management program will be used for the meet? Hy-Tek MM

20. Scoreboard: Will you have a team scoreboard for 1 - 15 places? yes

What type? Colorado Timing

21. What are the deck measurements? Left side 11' Right side 20'

Turning end 9' Behind start 17'

22. Total seating capacity in pool area 1200 (min of 1200 seating)

(min deck space 550-700)

Right side of pool 450 Left side of pool 300

Starting end n/a Turning end 100

Comments: additional seating space in adjacent warm-up pool area

23. Resting Area:

Is it convenient? Y Is it shaded? Y How large? attached sports arena seats 1200, plus floor space

Indoor/Outdoor? Indoor How far from the rest area to the pool? 50'

24. Locker Facilities: (20 swimmers + equipment min)

Women: # lockers _____ # showers 8 # toilets 13

Men: # lockers _____ # showers 8 # toilets 7

Separate restrooms for coaches and officials

25. P.A. System:

In pool area yes In warm-up pool area yes In locker rooms _____ In rest area Yes

Are acoustics acceptable if indoors? yes

Are speakers adequate if outdoors? _____

26. Will the facilities be available to only swimmers on a full-time

basis beginning one day before the meet? yes

27. Is a Certification of Pool Length Application on file at the United

States Swimming National Headquarters? to be submitted upon completion of construction

28. Do you have any policies that would restrict USA sponsorship

obligations? No

29. Per USA Swimming Rules and Regulations NO NOISE MAKERS WILL BE ALLOWED AT MEET.

30. Will meet marshals/Invigilators be available throughout the meet? yes

1. Hotel Headquarters:

Name: Address: City: State: Zip: See attached

Phone:(____) _____

Manager's Name: _____

Number of rooms:_____ Distance from hotel to pool: _____

Room rates: Single _____

Double: _____

Quad: _____

Describe facilities, including the restaurants and hours of operation: _____

2. Other Hotels:

Please attach a list of other hotels with the following information:

Name: Number of rooms: _____

Room rates: Single _____

Double: _____

Quad: _____

Driving time to pool: _____

Contact Name: Address: _____

Phone: (____) _____

3. Please indicate the number of restaurants in each category:

Fast food: 1-5 miles 50+ 6-10 miles 100+ 11-20 miles _____

Inexpensive: 1-5 miles 25+ 6-10 miles 100+ 11-20 miles _____

Moderate: 1-5 miles 20+ 6-10 miles 50+ 11-20 miles _____

4. Transportation To And From The City: _____

Airlines serving the city: All major airlines at DFW; Southwest and AA at Dallas Love Field

Distance from airport to the pool: 14.6mi Will there be free transportation from the hotels to the pool? no Schedule? _____

How many rental vans are available at the airport? unlimited

Car rental companies serving the city: all major companies

Is there a traffic problem getting to the pool from housing? no

If so, explain: _____



Prepared On: 08/12/2020
Prepared By: Kayla Gostnell

QUERY RESULTS - 19 RECORDS RETURNED

Account Name	Status	Boxed Meals	Group Menu's	Meeting Room: Space Type	Meeting Room Capacity	Offsite Catering	Takeout - Catering
J. Gilligan's Bar & Grill	Partner	No	No	Private	100	Yes	Yes
VIP Sports Bar & Grill	Partner	No	No	Flexible	98	Yes	Yes
VIP Sports Bar & Grill	Partner	No	No	Private	98	Yes	Yes
Babe's Chicken Dinner House	Partner	Yes	No	N/A		Yes	Yes
BoomerJack's Bar & Grill	Partner	Yes	No	Semi Private	65	Yes	Yes
Piccolo Mondo Italian Restaurant	Partner	No	Yes	Private	40	Yes	No
Prince Lebanese Grill	Partner	Yes	Yes	N/A	60	Yes	Yes
Buffalo Wings & Rings	Partner	No	Yes	N/A	0	Yes	Yes
Social House	Partner	No	Yes	Semi Private	100	Yes	No
Boston's Restaurant & Sports Bar	Prospect	Yes	No	Semi Private	80	Yes	Yes
Piranha Killer Sushi North	Prospect	Yes	Yes	N/A	0	Yes	Yes
Buffalo Wild Wings Grill & Bar	Prospect	No	No			No	No
Panera Bread	Prospect	Yes	No			Yes	Yes
Greasemonkey Burgers	Prospect	No	No			Yes	Yes
Lupe's Tex Mex Grill	Prospect	No	No			Yes	Yes
BFF Asian Grill & Sports Bar	Prospect	No	No			Yes	Yes
Vila Brazil Steak House	Prospect	No	Yes	Private	80	Yes	No
The Rock Wood Fired Kitchen	Prospect	No	Yes	Semi Private	100	No	Yes
Mercury Chop House	Prospect	No	No	Private	22	No	Yes



Prepared On: 08/12/2020
 Prepared By: Kayla Gostnell

QUERY RESULTS - 26 RECORDS RETURNED

Account Name	Rooms Total
817 Hotel, by Days Inn by Wyndham	93
Aloft Arlington Entertainment District	136
Baymont Inn & Suites by Wyndham	95
Candlewood Suites Arlington	125
Comfort Suites Arlington	108
Courtyard by Marriott Arlington	147
Days Inn by Wyndham	104
Extended Stay America	137
Fairfield Inn & Suites by Marriott	101
Four Points By Sheraton	102
Hawthorn Suites by Wyndham Arlington	129
Hilton Arlington	308
Hilton Garden Inn	132
Holiday Inn Arlington NE - Rangers Ballpark	147
Homewood Suites by Hilton	89
Howard Johnson by Wyndham	98
Hyatt Place Arlington	127
InTown Suites	133
La Quinta Inn & Suites Six Flags Drive	178
Live! By Loews	300
Ranger Inn & Suites	40
Red Roof Inn	100
Sheraton Arlington Hotel	311
Sleep Inn Arlington Near Six Flags	126
SpringHill Suites by Marriott	121
TownePlace Suites by Marriott	94



APPLICATION FOR SOUTHERN ZONE

AGE GROUP SWIMMING / SENIOR CHAMPIONSHIPS
(select one)

The __West Virginia__ Local Swimming Committee wishes to bid for the 2022_ Southern Zone Age Group Swimming / **Senior Championships** (select one).

____Renee Riggs
Chairman, Local Swimming Committee USA Swimming, Inc.

The organization that will be assigned the Championship is the:

NAME: Club Mountaineer Aquatics

ADDRESS: 218 Poplar Dr_____

CITY: _STATE: ZIP: Morgantown, WV 26505_____

PHONE: (304) 841-4391_____

The organization President is:

NAME: Vic & Renee Riggs_____

ADDRESS: Same as above____

CITY: STATE: ZIP: _____

PHONE: (304) 841-4391(R) 304-276-3477(V)_____

FACILITY INFORMATION

Please read and comply with the Southern Zone Meet Handbook and Article 103 - Facility Standards, USA Swimming Rules and Regulations. Please be certain you understand the requirements for hosting the meets.

If the organization is awarded these Championships, we propose to conduct the meet at the following facilities.

1. Name of Facility: The Aquatic Center @ Mylan Park_____

2. Name of Pool (if different): _____

3. Organization Administering Facility: Mylan Park Foundation__

4. Facility Administrator: Ed Denny_____

5. Address: 1847 Fitness Way_____

6. City: State: Zip: _Morgantown WV, 26501_

1. Phone: (304) 973-9733

2. Pool Street Address: Same

3. City: State: Zip: _____

8. The pool is 1 years old. It opened for the first time on Nov. 1st, 2019 (date).

9. The pool is: indoor _____ outdoor _____ indoor / outdoor

8. What is the depth of the pool? Start end:7'6" Center:7'3" Turn end:7'

Are all lanes the same depth? Yes. If not, explain: _____

Please sketch a profile of the pool bottom with the depths marked: Attached

9. There are 8 lanes for racing. Each lane is 9' wide.

10. Does the pool have a water heater? Yes A water cooling system? No not needed

11. Can you guarantee that the water will be the correct temperature range for competition? Yes with no current Yes.

12. What is the candlepower lighting three feet above the water with existing lights? 116 Candlepower at finishing and turning end? 116

13. Brand name of lane dividers Kiefer Advantage II

14. What type of gutter system is installed? Paddock Evacuator

15. Warm-Up Pool(s): (min of 6 lanes) Separate Diving Well

Length 25yds Width 20 yds Depth at Shallow end: 15'6"

Number of lanes 6 Width of lanes 7

Starting Platforms No Backstroke Ledges No

Indoor/Outdoor pool Indoor

Distance from competitive pool 14'

Will lane dividers be provided? Yes What type? Kiefer Advantage II

16. Starting platform information:

A. Size of platform surface Length 29" Width 20"

B. If slanted, the degree of slant Meets USA Swimming Guidelines

C. Height above water surface 2'5"

D. Are all surfaces non-skid Yes

17. Timing system trade name and model of automatic timing system: _____

_Colorado Timing System Gen 6_____

A. Is it installed or rented? Installed___

B. Name of touch pads _Colorado_

C. Name of back up system Colorado T.S._____

D. Where is it located? On site_____

E. Is a readout scoreboard installed? Yes If not will you rent one? _____

How many lines? Up to 16 lanes

18. Do you have, or will you have a sound starting device under each lane? Yes

19. Computerization: What computer system and meet management program will be used for the meet? Microsoft and HyTek Meet Manager

20. Scoreboard: Will you have a team scoreboard for 1 - 15 places? Yes

What type? Colorado_____

21. What are the deck measurements? Left side 16'8" Right side 16' to 19'

Turning end 12'7" Behind start 14'

22. Total seating capacity in pool area 1400 (min of 1200 seating)

(min deck space 550-700)

Right side of pool 250-300 Left side of pool 250-300

Starting end _N/A Turning end _TBD

Comments: _We have 10 sets of bleachers and will provide more if needed__

23. Resting Area:

Is it convenient? Yes Is it shaded? Yes How large? _____30'x29'6'

Indoor/Outdoor? Indoor How far from the rest area to the pool? Deck Access

24. Locker Facilities: (20 swimmers + equipment min)

Women: # lockers 110 # showers 11 # toilets 10

Men: # lockers 102 # showers 10 # toilets 5 toilets/6 urinals

25. P.A. System:

In pool area **Yes** In warm-up pool area **Yes** In locker rooms **Yes** In rest area **Yes**

Are acoustics acceptable if indoors? **Yes**_____

Are speakers adequate if outdoors? **N/A**_____

26. Will the facilities be available to only swimmers on a full-time basis beginning one day before the meet? **Yes**_____

27. Is a Certification of Pool Length Application on file at the United States Swimming National Headquarters? **Yes and see attached**_____

28. Do you have any policies that would restrict USA sponsorship obligations? **No**_____

29. Per USA Swimming Rules and Regulations **NO NOISE MAKERS WILL BE ALLOWED AT MEET.**

30. Will meet marshals/Invigilators be available throughout the meet? **yes**_____

1. Hotel Headquarters: **Courtyard by Marriott**

Name: Address: City: State: Zip: **460 Courtyard Way, Morgantown, WV, 26501**

Phone: **(304) 284-2186**_

Manager's Name: **Kimberly Thompson**_____

Number of rooms:_____ Distance from hotel to pool: **1.5 miles**

Room rates: Single **99.00**_

Double: **109.00**_

Quad: **124.00**_

Describe facilities, including the restaurants and hours of operation: **The Courtyard has a restaurant that is available for breakfast as well as a starbucks. They also offer catered meals and have meeting/eating rooms available. _**

2. Other Hotels: Please see attached. We have arranged Hotel rates with several Hotels

Please attach a list of other hotels with the following information:

Name: Number of rooms: _____

Room rates: ~~Double~~ Single: _____

Quad: _____

Driving time to pool: _____

Contact Name: Address: _____

Phone: (____) _____

3. Please indicate the number of restaurants in each category: Plenty of options

Fast food: 1-5 miles _____ 6-10 miles _____ 11-20 miles _____

Inexpensive: 1-5 miles _____ 6-10 miles _____ 11-20 miles _____

Moderate: 1-5 miles _____ 6-10 miles _____ 11-20 miles _____

4. Transportation To And From The City: Air- Pittsburgh International Airport

Airlines serving the city: Air Canada, Alaska Air, Allegant, American Airlines, Delta, Frontier, Jet Blue, Southwest, Southern Airways Express, Spirit, United

Distance from airport to the pool: 70 Miles

Will there be free transportation from the hotels to the pool? No Schedule?

How many rental vans are available at the airport? Unknown

Car rental companies serving the city: All major companies

Is there a traffic problem getting to the pool from housing? No

If so, explain: _____

VISIT MOUNTAINEER COUNTRY.com

Visit Mountaineer Country Convention & Visitors Bureau

August 7, 2020

Re: USA Swimming Southern Zone Championship 2022

Dear Selection Committee,

The Greater Morgantown area is extremely interested in hosting USA Swimming's 2022 Southern Zone Championship. We feel that our destination is well suited to meet your event needs of transportation, hotels, and amenities located in "Almost Heaven" West Virginia.

Morgantown is located in North Central West Virginia and strategically located at the intersection of Interstate 79 and 68. Although we may be at the northern most edge of your Southern Zone territory, we are serviced by three airports and within an easy day's drive of almost 20% of the United State's population. Pittsburgh International Airport is 80 miles north of Morgantown. It is serviced by 14 airlines and has a \$1.1 billion renovation planned to be completed by 2023. North Central West Virginia Airport is 30 miles south of Morgantown and is serviced by United Airlines and Allegiant Airlines. The third airport servicing Morgantown is the Morgantown Municipal Airport which is serviced by Southern Airways who flies multiple flights daily to Pittsburgh International Airport and Baltimore/ Washington International Airport. Transportation to and from the airports servicing the Greater Morgantown area is available as needed.

Numerous lodging options are also available. Many of the major hotel chains are in our marketplace and have a wide range of options from full-service Marriott, multiple midrange Marriott, Hilton, and Choice International properties, to economy brands. The vibrant local economy frequently attracts new properties to add to Morgantown's more than 30 lodging properties that provide more than 2,500 room nights daily. Lodging options are located throughout the Morgantown area, providing various venues from downtown properties close to WVU's Main Campus to properties located at our multiple shopping developments as well as interstate properties. We also have multiple restaurants and retail establishments such as Dick's Sporting Goods, Sam's Club, Walmart, and Target in very close proximity to our athletic facilities. This nucleus of retail and hospitality options makes our location very favorable for the tournaments and large-scale events.

Being the home of the West Virginia University Mountaineers, creates a robust sports environment. Mountaineer Country has multiple organizations that work collaboratively to advance more than \$61M of sports development projects since 2015. The two major projects were the Monongalia County Ballpark, and the Aquatic Center and Track and Field Complex at



Mylan Park. Organizations involved in bringing these projects to completion included, but are not limited to, the City of Morgantown, the Monongalia County Commission, the City of Westover, the Town of Granville, Star City, West Virginia University, West Virginia University Hospitals, The Partnership of Greater Morgantown (Chamber, Economic Development Authority, and an urban development organization), local private foundations, Visit Mountaineer Country Convention and Visitors Bureau, the West Virginia Department of Commerce, the West Virginia Governor's Office, and numerous local businesses. The Monongalia County Ballpark involved Tax Increment Financing and opened in 2015. The Aquatic Center and Track and Field Complex at Mylan Park, involved extensive collaborative public and private financing and opened in 2019.

The most recent facilities developed were the Monongalia County Ball Park, home of the West Virginia Blackbears, and the Aquatic Center and Track and Field Complex at Mylan Park. These cutting-edge facilities were designed, developed, and financed by extensive cooperative efforts of local community partners, private, and public resources. Mylan Park also has additional facilities that are a prime destination for competitive sports. These include baseball, softball, soccer, multipurpose fields, cross country track, a miracle field, and more than one indoor facility. All of the facilities and activities are part of the reason that Morgantown has been recognized as the one of the "30 Best Small Sports Cities" in the U.S. according to Wallet Hub.

Another area of interest to you may be our healthcare facilities and programs. Healthcare is one of the larger segments of our local economy. West Virginia University Medical School, WVU Medicine's J.W. Ruby Memorial Hospital, and Mon Health Systems all reside locally and provide cutting edge care throughout the region. Ruby Memorial Hospital is the level 1 trauma center in North Central West Virginia. In addition, sports medicine has been integrated throughout the community for decades and continues to advance through their community outreach programs. You will find that our healthcare network would be a great partner in providing any care that might be needed during your 2022 Southern Zone Championship.

Amenities of our "Almost Heaven" home are numerous. It is no wonder that West Virginia has been referred to as the Grand Canyon of the East Coast. Our scenic beauty and outdoor activities are impressive. Hiking, biking, whitewater, kayaking, fishing, rock climbing, boating abounds throughout the region. Visitors come to Morgantown, acknowledged as the "Tastiest Town" in West Virginia by the Charleston Gazette, to have a great time and that is what they get. Whether you are seeking the arts in a museum, on a public street, or by watching a live performance; sports in the form of an organized run, a game at the Monongalia County Ballpark, or an adventure in the great outdoors; or attending a conference at one of our many meeting locations, we have all of the bases covered and more. Our VisitMountaineerCountry.com regional events calendar is full of special events and activities to entice guests to stay one more day and share in the local experiences.

At VMCCVB, we advance our tourism economy by marketing and selling the destination to our guests by "wowing" them with our secret ingredient, Mountaineer Country hospitality. In order

to do so, we are actively engaged in small to large-scale events. Whether it is booking rooms, assisting with group requirements, building itineraries that inspire families to enjoy an escape in our region's outdoors and culture, or coordinating tours to showcase top attractions, we are happy to assist. If we secure your 2022 Championship, Visit Mountaineer Country CVB would provide you a customized event portal to function as a one stop shop for all of your attendees to find event, local, and travel information needed to make their experience one that would make them say "Wow!".

We hope to have the opportunity to further explore our destination as your future home of the USA Swimming Southern Zone Championships 2022. Below are links to several Mountaineer Country resources that you may find helpful. Please feel free to reach out to me directly at 304-292-5081 or Susan@VisitMountaineerCountry.com with any questions and we look forward to the opportunity.

<https://www.visitmountaineercountry.com/thumbs-up-in-greater-morgantown/>

<https://www.visitmountaineercountry.com/sports-planners/>

<https://www.visitmountaineercountry.com/102-things-to-do-in-greater-morgantown/>

<https://www.visitmountaineercountry.com/stay/morgantown/>

<https://www.morgantownpartnership.com/>

Sincerely,

A handwritten signature in blue ink that reads "Susan Riddle". The signature is written in a cursive, flowing style.

Susan Riddle, President & CEO

Attachment: Mylan Park Fact Sheet

MYLAN PARK

in partnership with
West Virginia University

The Aquatic and
Track Center

MORGANTOWN, WV



Track & Field Complex Opened October 2018
Aquatic Center Opening September 2019

“This Center is important for several reasons. Not only does it significantly improve the University’s swimming, diving, cross country and track programs, it also provides an important addition to the recreational options in Monongalia County and beyond.”

- **Shane Lyons**, Associate Vice President and Director of WVU Intercollegiate Athletics

Mylan Park retained CENTERS, LLC to manage its entire park property including the Aquatic and Track Center. The community wellness facility features a competitive and community pools as well as a track and field complex that will be used by West Virginia University, local high schools, and the surrounding community. As one of the main tenants of park properties, CENTERS will work closely with WVU to ensure its students are given the use of outstanding facilities for its Sport Club and Intramural programs as well as its Track and Aquatics teams in University Athletics. WVU Recreation regularly uses the Hazel and J.W. Ruby Community Center and outdoor fields for its Sport Club and IM programs and WVU Athletics Track and Aquatics teams will train and compete in the Aquatics and Track Center year round.

Mylan Park is a state-of-the-art recreational and educational complex located on over 300 acres of beautifully reclaimed surface-mined property just minutes from downtown Morgantown, West Virginia. The Mylan Park Foundation, Inc. advances the educational, recreational, social and economic benefits to North Central West Virginia citizens, with the purpose of improving the quality of life for residents of, and visitors to, the Greater Morgantown area.

Planning
Brailsford & Dunlavey, Inc.

Operations
CENTERS, LLC

Design Architect
Paradigm Architecture, Inc.

Contractor
March-Westin Company

\$40M
Project Cost

97,000 SF
Building Size/Program

TRACK AND FIELD COMPLEX LAYOUT

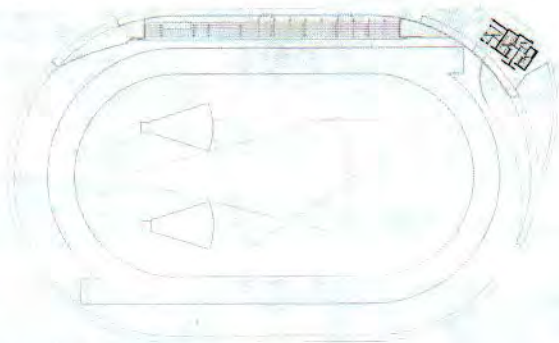

AQUATIC CENTER LAYOUT

LEVEL 1



LEVEL 2

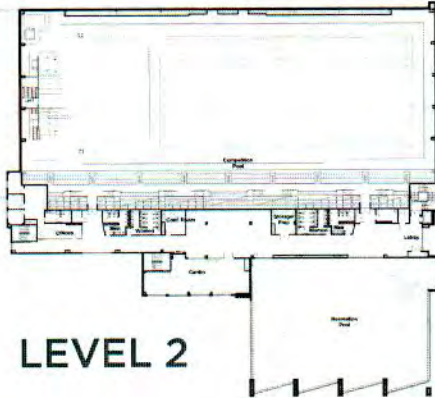

FEATURES:

TRACK AND FIELD COMPLEX

4,000 meter, 9-Lane Track and Field Complex

Steeple Pit, Pole Vault, Long Jump, High Jump, Shot Put, Javelin, and Hammer/Discus Areas

Spectator seating for 1,200

Press box

Ticket office and offices

Restrooms

Concessions

AQUATIC CENTER

50 meter Competition Pool with spectator seating for 2,000

Diving Tower

25 yard, 6-Lane Recreational pool with splash and play features

Outdoor splash pad

Wet Classroom/Multipurpose Studios (dividable into 2 rooms)

Fitness center

Retail pro shop

Indoor/outdoor concessions

Catering Kitchen

PARTNERS

West Virginia University

West Virginia University Hospitals, Inc.

West Virginia University Athletics

ADDITIONAL PARK FEATURES

- » 53,000 square foot Community Center
- » Athletic Field Complex and Special Events area featuring:
 - » 100 yard Turf Athletic Field
 - » Two Grass Baseball Fields
 - » Two Grass Softball Fields
 - » Two Turf Baseball/Softball Fields
 - » 12,000 square foot Outdoor Event Pavilion
 - » 24 Horseshoe Courts
 - » RV Parking Lot
 - » Miracle Baseball League - Adaptive Field Complex



MYLANPARK.ORG

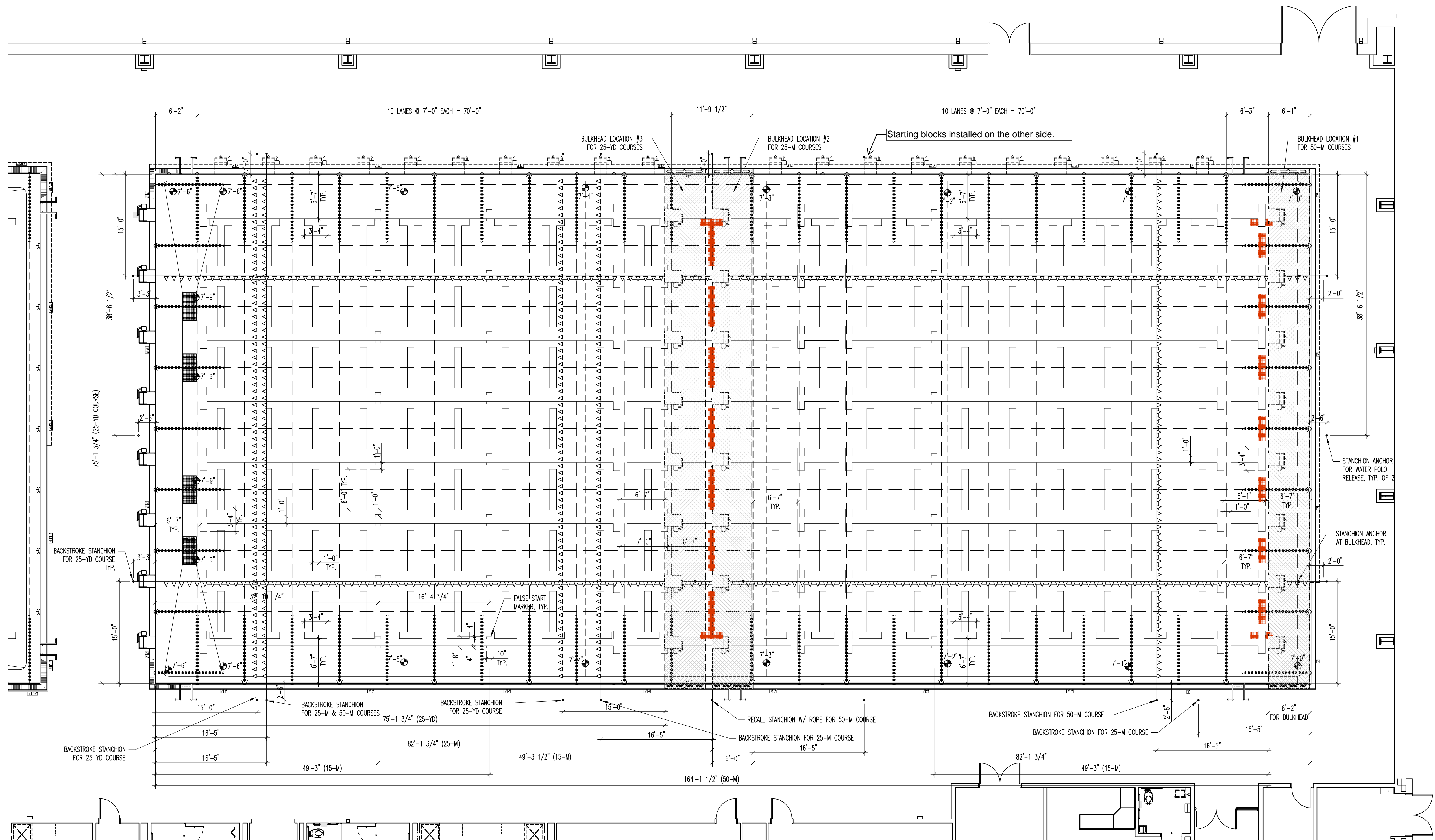

LAP POOL RACING COURSE PLAN
SCALE: 1/8"=1'-0"

MOUNTAINEER CENTER FOR
WELLNESS & AQUATIC CENTER
MYLAN PARK LANE
MORGANTOWN, WV. 26501
LAP POOL RACING
COURSE PLAN



15120-C SOUTHLAWN LANE ROCKVILLE, MD. 20850
PHONE: (301)-424-0790 EMAIL: info@paddockpools.com

THESE DRAWINGS, AS INSTRUMENTS OF SERVICE, ARE THE PROPERTY OF PADDOCK SWIMMING POOL CO., AND ARE NOT TO BE COPIED IN ANY FASHION WITHOUT APPROPRIATE CONSENT.

REVISIONS:	SCALE: 1/8" = 1'-0"	JOB NO.:
	DATE: 06/01/2018	SHT. NO.:
		1.4

REVISIONS			
ZONE REV.	DESCRIPTION	DATE	APPROVED
P1	INITIAL RELEASE	1/23/2018	J.HANKEL
P2	CHANGED DIMENSIONS	1/29/2018	N.RACKLEY
P3	CHANGED W.D.	1/30/2018	J.HANKEL
P4	ADDED SLOPE	1/31/2018	J.HANKEL

FRAME ONLY. TOP NOT INCLUDED

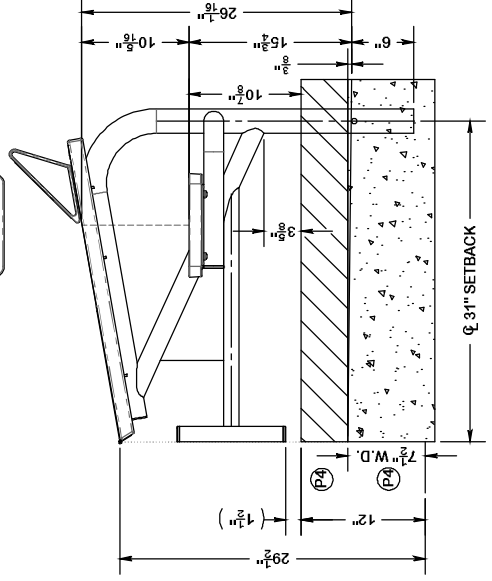
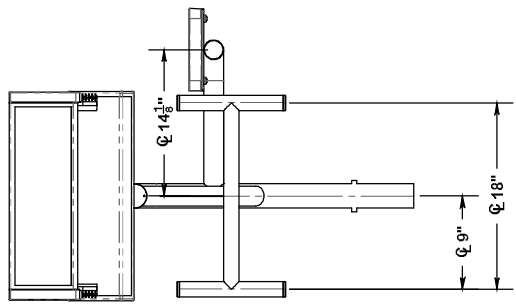
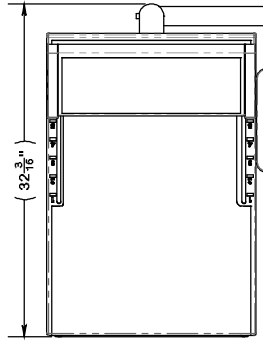

NOTE
THIS STARTING PLATFORM MEETS FINA CODE FR2.5, USS CODE FR2.5, NSS CODE 103.13.1-6, AND NCAA ARTICLE 7. IF YOU HAVE ANY QUESTIONS PLEASE CALL: SPECTRUM PRODUCTS @ 1.800.791.8056...**UPDATED: SEPTEMBER 17, 2012**
Rule 2.7 - 2012-13 FHHS SWIMMING RULES...PAGE 12
Backstroke grips shall be no more than 30 inches (762mm) above the water surface and shall be set at an angle of 10 degrees from the horizontal. It is recommended the top be a minimum of 20 inches square (508 mm) and covered with a nonskid material.
MAXIMUM Height of Platforms/Decks Above Water Surface 30"

FINA CODE FR 2.7 Starting Platforms
The platform above the water surface shall be from 0.5 metre to 0.76 metres. The surface area shall be at least 0.5 metre x 0.5 metre and covered with non-slip material. Maximum slope shall not be more than 10°. The starting platform may have an adjustable setting back plate. The platform shall be constructed so as to permit the gripping of the platform by the swimmer in the forward start of the front and the sides. It is recommended that the platform be at least 0.4 metre wide and 0.4 metre high at least 0.1 metre within the edge of the platform. Handgrips for the forward start may be installed on the sides of the starting platforms. Handgrips for backstroke starts shall be placed within 0.3 metre to 0.6 metre above the water surface both horizontally and vertically. They shall be parallel to the surface of the end wall and must not protrude beyond the end wall. The water depth from the surface of the platform to 6.0 metres shall be at least 1.35 metres. The platform shall be installed under the blocks. Flashing is not allowed. Figures must not move during a backstroke start.

NCAA Article 7 Starting Platforms
The platform shall not exceed 30 inches (76.20 cm) in height above the surface of the water and shall not extend over the water beyond the end of the racing course. The length of the starting platform should not be less than 20 inches (50.80 cm) and may not be more than 34 inches (86.36 cm). The width of the platform should be a plane less than 20 inches (50.80 cm). The top of the platform must be a plane surface, and the maximum slope of the surface toward the water shall not be more than 10 degrees. The top surface shall be covered with a nonskid material. The top surface shall be visible on both sides of the platform. Firm starting grips for backstroke starts must be provided. These grips shall be located not more than 30 inches (76.20) above the surface of the water. They shall not extend over the water beyond the end of the racing course.

USA SWIMMING 103.13/M/ STARTING PLATFORMS

- Height.**
 - A. Long course and short course meters: The front edge of the starting platform shall be no less than 0.50 meters (1 foot 8 inches) nor more than 0.75 meters (2 feet 5 1/2 inches) above the surface of the water.
 - B. Short Course yards: The front edge of the starting platform shall be no higher than 2 feet 6 inches (0.72 meters) above the surface of the water.
- The front edge of the starting platform shall be flush with the face of the end walls.
- The top surface of the starting platform shall be no less than 0.50 by 0.50 metres (1 foot 8 inches) and shall be set at an angle of 10 degrees from the horizontal. It may have an adjustable setting back plate. The entire surface of the platform shall be faced with permanent nonslip material.
- Backstroke starting grips: Starting platforms shall be equipped with firm starting grips located between 0.3 meters (12 inches) and 0.6 meters (24 inches) above the water surface. The front edge of the grips shall be parallel to and flush with the face of the end wall.
- Starting platforms shall be clearly marked with lane numbers visible to competitors and officials.
- Starting platforms shall be anchored to the deck or bulkhead to remain stable at all times.

NOTE:
UNLESS OTHER PROVISIONS ARE MADE AT THE TIME OF SUBMISSION, SPECTRUM PRODUCTS SHALL NOT BE RESPONSIBLE FOR DELAYS OR CHARGES FROM WORK IN PROGRESS. HOURS OF RECEIPT TO AVOID CHARGES FROM WORK IN PROGRESS.

PRELIMINARY DO NOT FABRICATE

CUSTOMER: X	MATERIAL: 316L STAINLESS STEEL
FINISH: PASSIVATED IAW ASTM A967	
<p>PROPRIETARY AND CONFIDENTIAL THE INFORMATION CONTAINED IN THIS DRAWING IS THE SOLE PROPERTY OF SPECTRUM PRODUCTS LLC. ANY REPRODUCTION IN PART OR AS A WHOLE WITHOUT THE WRITTEN PERMISSION OF SPECTRUM PRODUCTS LLC IS PROHIBITED.</p>	
<p>BY: _____ DATE: _____</p> <p>YOUR SUBMITTAL TO SPECTRUM PRODUCTS HAS IMPLICITLY ACCEPTED THE TERMS AND CONDITIONS OF THIS SUBMITTAL. PLEASE REVIEW THIS SUBMITTAL THOROUGHLY. SPECTRUM PRODUCTS CANNOT BE RESPONSIBLE FOR ERRORS MADE BY THE SUBMITTOR. YOUR CUSTOMER PLEASE INSURE ALL DIMENSIONS ARE ACCURATE AND CORRECT. IT IS THE SOLE RESPONSIBILITY OF THE CUSTOMER TO ENSURE THAT THE PRODUCT MEETS ALL APPLICABLE CODES.</p>	<p>DO NOT SCALE DRAWING THIRD ANGLE PROJECTION</p>
<p>UNLESS OTHERWISE SPECIFIED: DIMENSIONS ARE IN INCHES TOLERANCES: FRACTIONS: 1/16 ANGULAR: ± 1° X.XX ± 0.01 X.XXX ± 0.005</p>	<p>DEBUR AND BREAK SHARP EDGES</p>

7100 SPECTRUM LANE
MISSOULA, MT 59808
4061 542-9781
4061 542-1158

TEL: MYRTHA - SP - 12" BULKHEAD
31" SETBACK 7 1/2" W.D. LEFT STEP

SIZE: B	DWG. NO.: 1890063	REV: P4
SCALE: 1:12	WEIGHT: 81.10	(SEE 1 OF 1)

Pool Length Certification Form (rev. 10/17/2017)

Measurement procedures for completing this form are found on the next page. Please review them before measuring your pool and submitting this form. Only this side needs to be submitted for your pool certification.

1. Facility

Pool Name Mountaineer Center for Wellness & Aquatic Center
 Address Mylan Park Lane
 City Morgantown State WV Zip 26501
 LMSC _____

Pool Length		
25 Yards	25 Meters	50 Meters
Moveable Bulkhead		
Yes	No	
Number of Touchpads in place at time of the measurement		
Zero	One	Two

Note: For facilities with multiple pools, please identify the specific pool being measured either by unique pool name within the facility or the pool location in relation to other pools within the entire facility.

2. Measurement parameters (circle answer)

- a. Measuring device (see instructions): Steel tape? Laser? Other _____
- b. Distances measured in (check one):
- feet with feet displayed as a decimal to 1/100 like 75.01 feet
 - feet/inches with inches displayed as a fraction to 1/8 like 75ft 3/8 in.
 - meters with meters displayed as a decimal to 1/100 like 50.01m
 - meters/centimeters with centimeters displayed as 50m 1cm.

3. Measurements ALSO SEE EXHIBIT "A" Date of Initial Measurement: 10/16/2019

A. Initial Measurement: Complete this section with measurement of all lanes if the pool has never been measured.

Lane 1 164.143' 50.030M Lane 2 164.126' 50.023M Lane 3 164.135' 50.025M Lane 4 164.118' 50.020M
 Lane 5 164.132' 50.024M Lane 6 164.116' 5.020M Lane 7 164.122' 50.021M Lane 8 164.116' 50.020M
 Lane 9 _____ Lane 10 _____ Lane 11 _____ Lane 12 _____

B. Bulkhead Confirmation Measurements: (per Rule 105.1.7)

Measure the outermost lanes and a center lane before the meet plus after each session with lane number & length of the lane.

	Date	L-Outer Lane #	Left Outer Lane Length	Center Lane #	Center Lane Length	R- Outer Lane #	Right Outer Lane Length
Pre-meet							
Post session 1							
Post session 2							
Post session 3							

4. Measured by:

Name Dave Unger
 Title Professional Land Surveyor, MD #21236
 Address 20251 Century Blvd, Suite 400
 City/State/ZIP Germantown, MD 20874
 Phone Number 301-916-4100

Submitted by:

Name _____
 Title _____
 Address _____
 City/State/ZIP _____
 Phone Number _____

Maintaining pool length certification forms is an LMSC responsibility. Completed forms should be sent to the Top Ten Recorder of the LMSC. Attach a copy of this form to record applications if the form is not already on file with the USMS National Swims Coordinator. If a bulkhead is used, a copy of this form from the beginning of the meet and for each session must be included with meet results sent to the LMSC Top Ten Recorder in order to verify bulkhead placement. For a record application, the bulkhead measurement on this form should be attached to and submitted with the Record Application form. To add the pool to the USMS List of Measured Pools, e-mail a copy of this form to Mary Beth Windrath, National Swims Coordinator, records@usms.org. Measure before applying for a sanction.

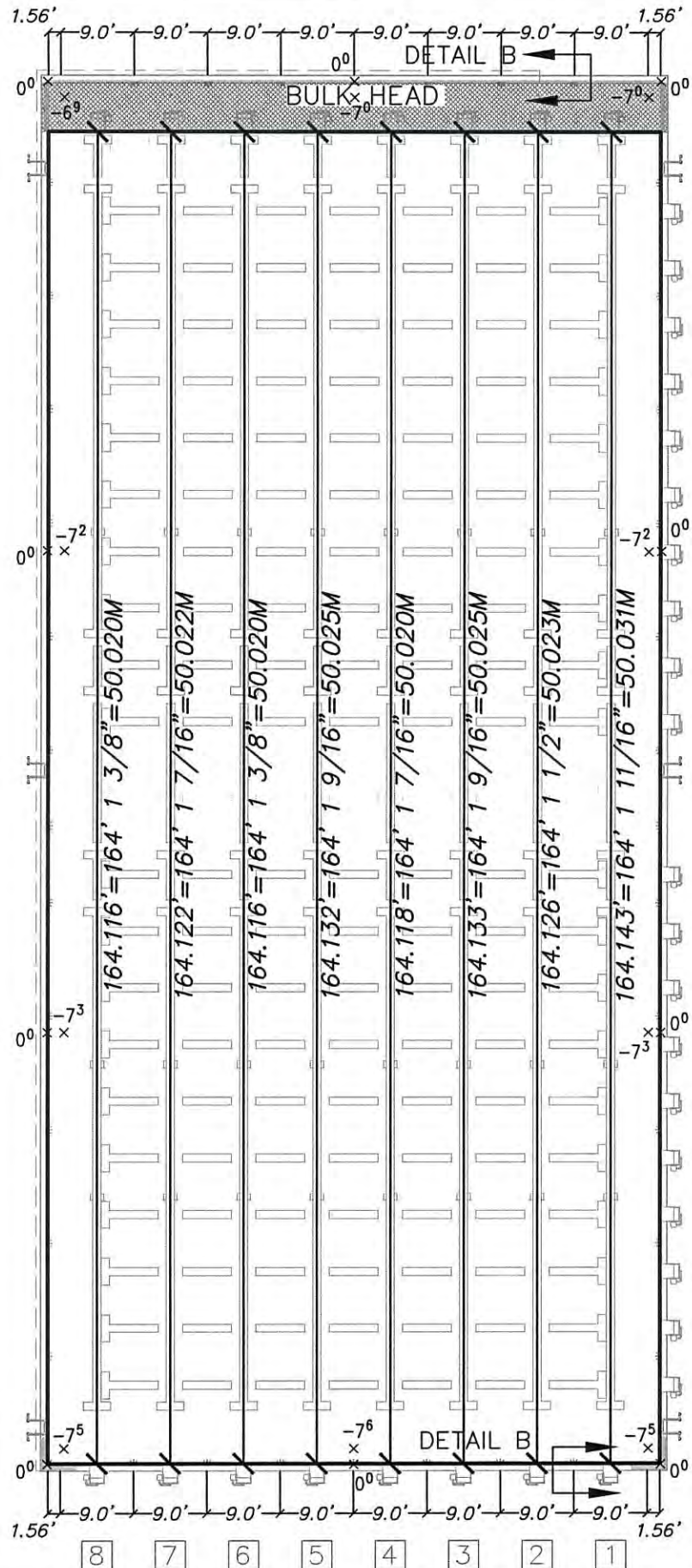

David F. Unger II

NOTES:

- 1.) LENGTH OF LANES HAVE BEEN ESTABLISHED PER USA SWIMMING REGULATIONS, RULES 103.3.1.C AND 104.2.2.C.
- 2.) WIDTH OF LANES HAVE BEEN MEASURED BETWEEN THE ROPE ANCHORS FOR POOL DIVIDERS.
- 3.) ALL ELEVATIONS ARE ASSUMED. SPOT GRADES (x^{-72} OR x^0 , SHOWN IN U.S. SURVEY FEET) BASED ON SPILLWAY (WATER LEVEL) OF 0.00'.
- 5.) x^{-72} DENOTES DEPTH OF POOL BELOW TOP OF SPILLWAY.

EXHIBIT "A"

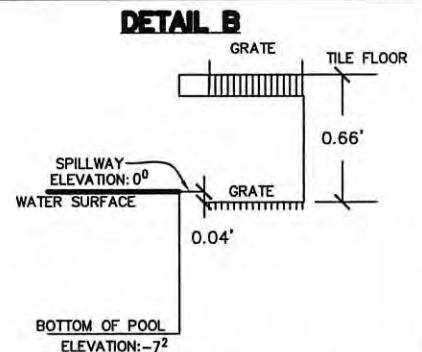

MOUNTAINEER CENTER FOR WELLNESS

POOL AS-BUILT

EXHIBIT "A" 50 METERS

SURVEYED: 10/16/19 SCALE: 1"=20'



ENGINEERS ■ PLANNERS ■ LANDSCAPE ARCHITECTS ■ SURVEYORS ■ SUSTAINABLE DESIGN

20251 CENTURY BOULEVARD-SUITE #400 ■ GERMANTOWN, MARYLAND 20874
(301) 916-4100 ■ FAX (301) 916-2262

2022 USA Swimming Southern Zone 12% Sales and Occupancy Tax Nightly

Property	Rating	Phone	Single, Double, Suites	Added Amenities Near By	Shuttle	Complimentary Breakfast	Complimentary Wifi	Complimentary Parking	Mylan Park and Aquatic Center
Courtyard	3 Star	304-599-1080	HEAD QUARTER HOTEL \$99.00/\$109.00/\$124.00 1 COMP ROOM AND ADDITIONAL 1 COMP PER NIGHT PER 25 ACTUALIZED	Shopping and Restaurant	Yes	Restaurant	Yes	Yes	1.5 Mile
Best Western	2 Star	304-599-5399	\$59.00 Single or Double	Shopping and Restaurant		Hot Breakfast	Yes	Yes	3 Miles
Candlewood	3 Star	304-241-2411	NO BID	Shopping and Restaurant	No		Yes	Yes	1.2Miles
Econo Lodge	2 Star	304-296-8774	\$69.99/\$89.00 Single & Double	Shopping and Restaurant		Rate includes Hot Breakfast			4.9 Miles
Euro-Suites	3 Star	304-598-1000	\$90.00/\$90.00/\$100.00	Shopping and Restaurant	Yes	YES	Yes	Yes	4.2 Miles
Fairfield Inn & Suites	2 Star	304-532-5006	\$85.00/\$99.00/ \$99.00 COMP ROOM AND ADDITIONAL 1 COMP PER NIGHT PER 25 ACTUALIZED	Shopping and Restaurant	Yes	Rate includes Hot Breakfast	Yes	Yes	2 Miles
Hampton Inn and Suites	3 Star	304-598-0600	\$99.00 Double or Single	Shopping and Restaurant	No	Rate includes Hot Breakfast	Yes	Yes	2.7Miles
Holiday Inn University	3 Star	304-241-6649	\$109.00/\$119.00/\$129.00	Shopping and Restaurant	Yes	Rate includes Hot Breakfast	Yes	Yes	5.2Miles
Hilton Garden Inn	3 Star	304-225-9500	\$84.00/\$102.00	Shopping and Restaurant	No	Rate includes Hot Breakfast	Yes	Yes	6.4Miles

La Quinta Inn	2. Star	304- 241-4501	\$99.00 Single or Double	Shopping and Restaurant	No	Rate includes Hot Breakfast	Yes	Yes	1.2Miles
Motel 6	2 Star	304-599-8181	\$89.00 Single or Double	Shopping and Restaurant		Rate includes Hot Breakfast			3.2Miles
Scholar Hotel	3 Star	304-777-4100	NO BID	Shopping and Restaurant	No		Yes	Yes	5.3 Miles
SpringHill Suites	3 Star	304-225-5200	NO BID	Shopping and Restaurant	No		Yes	Yes	5.2Miles
Super 8	2 Star	304-296-4000	\$69.00/89.00	Shopping and Restaurant	No	Rate includes Hot Breakfast	Yes	Yes	6 Miles
Suburban	2 Star	304-291-2535	No BID	Shopping and Restaurant	No		Yes	Yes	5.2Miles
SureStay Plus/Westover	2 Star	304-292-0055	\$79.00 Single or Double	Shopping and Restaurant	No	Rate includes Hot Breakfast	Yes	Yes	5.3Miles
Waterfront Place	4 Star	304-296-1700	Single/Doubles \$159 nightly plus taxes Suites would be \$209 nightly plus taxes; hotel can only offer 2 suites	Shopping and Restaurant	Yes	Restaurant	Yes	NO	5.2Miles

2019-2020 Report

Southern Zone Diversity, Equity, and Inclusion Coordinator

This year saw the implementation of new governance structures within USAS and the LSCs represented. By the beginning of 2020, all of the Southern Zone LSCs reported updating their governance structures and several made changes to how they positioned Diversity, Equity, and Inclusion (DEI) within that structure. For several LSCs, DEI became a member of the Board of Directors (BOD) for the LSC – congratulations to Florida Gold for making the DEI a voting position. South Carolina is submitting legislation in their October HOD to have DEI become a voting member! Goal: increase that to over half of SZ LSCs.

Many LSCs are actively engaging their athletes in DEI. Kentucky had its first ever athlete leadership workshop (KYLEADS) in December. Athletes from across the state gathered to discuss DEI, Personal Leadership, and to form a working athlete committee for the LSC. Florida swimming has athlete reps for each of its six areas. South Carolina Swimming has an active athlete DEI committee that's meeting monthly. The LSC is also hoping to have a combined senior, age group, and open water DEI virtual camp September 18-20. Goal: have more than half of LSCs form an athlete DEI committee or have an athlete representative on the LSC DEI committee.

Communication is key, especially in the strange times that 2020 became in March with Covid shutdowns. Both Florida and South Carolina report making/updating DEI tabs on their LSC websites. Florida is developing a plan for DEI information placement in heat sheets. Most of the LSCs utilize virtual meetings to stay updated (Zoom, Facebook live, etc). I continue to share to our Southern Zone DEI Facebook page information regarding issues related to DEI. Goal: have a virtual Zoom/Facebook live meeting for the LSC DEI chairs quarterly.

Camp update for 2021: No information at this time from USAS on Zone DEI Select Camp (if they will be held/where/when to be held).

The National DEI Committee is actively formatting a virtual meeting program for the 2020 USAS Annual meeting. As the SZ DEI Coordinator, I am involved in that planning but nothing is defined at this time.

2020 Disability Report

Southern Zone

The responsibilities of the disability coordinator include disseminating information related to swimmers with a disability to all LSCs. Since this position had been unfilled for an indeterminate length of time, the first task was to create a contact list to determine who should be the point of contact for this information. All 15 LSCs were contacted. 9 have a designated disability chair, 1 is in the process of replacing the chair, 4 do not have a disability contact and 1 has no contact information at all. Information will be sent to the general chair where no contact is available.

Several issues regarding disability swimmers and competitions were referred to me and I was able to secure answers to those questions. Then everything stopped.....

All events and activities beginning in March were postponed or cancelled. In July, Us Paralympic Swimming released a plan to return to training and preparing for the now postponed Olympic and Paralympic games. By mid-August each of those events were withdrawn. At this time there are no scheduled events confirmed.

The national disability committee and paralympic swimming have been meeting virtually this entire time. They have put on 3 virtual clinics for parents, swimmers and coaches. An official's clinic is planned for later this year. The alternate time standards for disability swimmers are being reviewed and adjusted, scholastic All-American standards were submitted for disability swimmers, and time standards above the sectionals level are being formulated.

The USOPC has consolidated staff services and updated the web sites. Disability information can be found at www.teamusa.org. Select sports, then summer, scroll down. Swimming and paraswimming are listed side-by-side. All updates will be posted here when they are available. I will push this information to the LSC contacts as well. If anyone would like to be added to this list send me an email and I will send it to you directly.

If there are any questions or information that I can assist with, please don't hesitate to contact me. I will find an answer or refer you to the person who has one.

Rayleen Soderstrom
SoderstromRayleen@gmail.com

SOUTHERN ZONE SAFE SPORT REPORT
SEPTEMBER 12, 2020

SAFE SPORT RECOGNITION AS OF 8/31

SOUTHERN ZONE LEADS IN NUMBER OF TEAMS SAFE SPORT RECOGNIZED – 157

SOUTHERN ZONE LAST IN NUMBER OF TEAMS STARTED SAFE SPORT RECOGNITION – 111

WE HAVE 3 LSCs IN TOP 10 TEAMS

1	Florida	49
2	NC	35
6	GA	19

USAS INITIATIVE OF KEEPING ATHLETES FIRST is focused on SSRP and is providing an opportunity to win a visit from a NATIONAL TEAM MEMBER with a monthly drawing through December 2021 for those clubs that obtain SSR.

Our LSC Safe Sport coordinators are doing a great job of promoting safe sport within their LSCs. LET'S BE THE FIRST ZONE TO HAVE AN LSC WITH 100% SSR CLUBS!

BECOME SAFE SPORT RECOGNIZED IN FOUR SIMPLE STEPS

1. Ensure the public main page of your website has a safe sport tab
2. Upload the required personalized documents provided to your club
3. Attend USAS zoom education with Liz or have athletes and parents complete the education on the USAS website
4. Go to USAS, enter your club portal, complete the safe sport recognized club application, and submit

If you would like assistance completing the application in your club portal, you may allow another person access only to the application. Please see the document below.

Access Club Portal

- Step 1. Login to your DeckPass Step 2. In the top toolbar choose Safe Sport
In the drop down select Safe Sport Recognition Program

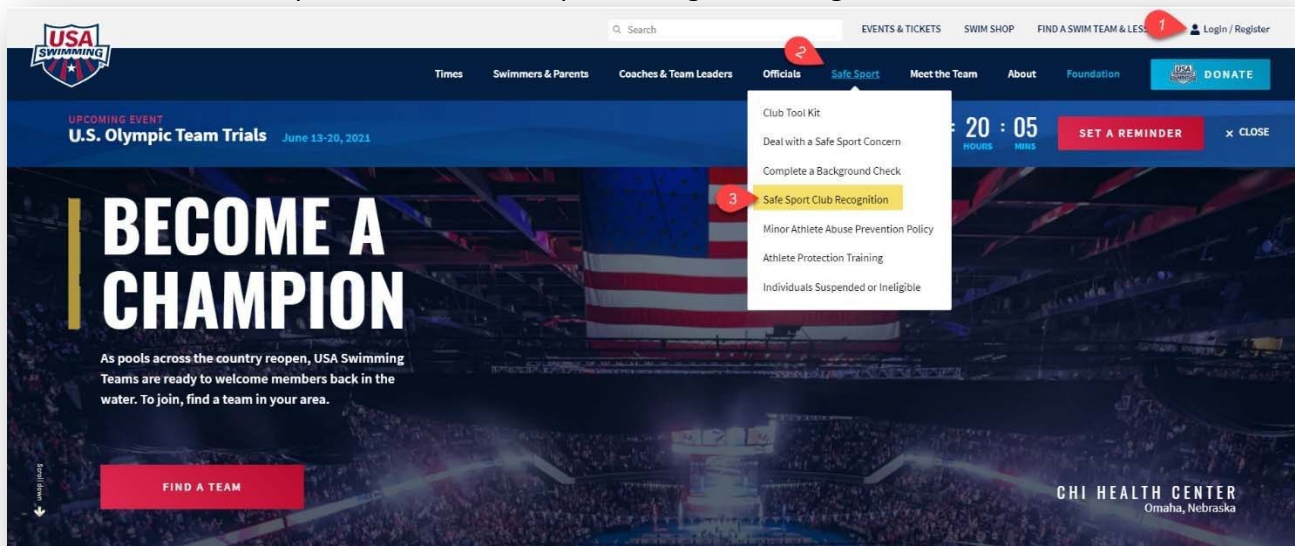

Step 3.

- Step 4. Scroll down and select "Access Club Portal"

POPULAR RESOURCES
CLUB PORTAL

INSTRUCTIONS

- At the search window enter your club code, club name or use the drop-down box to find your Local Swim Committee (LSC) and click SEARCH
- After the SEARCH has been executed click on the CLUB PORTAL to go the Club Portal area or LSC PORTAL to go to the LSC Portal.
- Note the blue tabs labeled Announcements, Practice Schedule, Upcoming Meets, Meet Results and Facilities. All of the contents of these tabs are viewable to the public. The Report tab (on the far right) is only viewable if logged in as the Club Administrator.
- To log in as the Club or LSC Administrator, get the Club Portal password. The Club Portal password was sent to the Head Coach. Then scroll to the bottom and click on Club Administrator Login (you must be logged into the USA Swimming website to see this login).
- Fill in the club password and click on Edit Club Portal. If you do not know your club portal password you may contact USA Swimming.
- Once logged in the default view is the Reports tab
- To access the Club Recognition Program, click on the Home tab then Go To Club Recognition

If you need assistance accessing your portal or need the portal password please contact USA Swimming at sportdevelopment@usaswimming.org.

5 [OPEN CLUB PORTAL](#)

SAFE SPORT CLUB RECOGNITION

EVERY CLUB CAN JOIN
SAFE SPORT CLUB RECOGNITION PROGRAM

The USA Swimming Safe Sport Club Recognition program allows a USA Swimming member club to demonstrate its commitment to creating a healthy and positive environment free from abuse for all its members through the development and implementation of club governance measures, Safe Sport policies and reporting mechanisms, Safe Sport best practices and training to athletes and parents.

4 [ACCESS CLUB PORTAL](#)

Step 5. Next page, click on “Open Club Portal”

Step 6. Type in your club name

Step 7. Click on search

Step 8. Select your club from the results and click on “Club Portal”

CLUB SEARCH

Club Name: 6

Club Code:

City:

Zip Code:

State:

Local Swim Committee (LSC):



Club Recognition Level:

Club Excellence Level:

Safe Sport Level: Recognized

[SEARCH](#) 7

SEARCH RESULTS

Club Name	LSC Id	City	State	Zip	Level	Options
Aces Aquatics	NE	Billerica	MA	01824		Club Portal LSC Portal
Aces Swim Club	CO	Englewood	CO	80112	 	8 Club Portal LSC Portal

1

Step 9. Scroll to the bottom of the screen and click on “Club/Safe Sport Administrator Login”

HEAD COACH

CLUB COACHES

[CLUB / SAFE SPORT - ADMINISTRATOR LOGIN](#) 9

Step 10. Enter your email, phone number and the administrator password. Then click on “Edit Club Portal/Safe Sport Login”

Please verify your email address and phone number

Email:

Phone #:

Club Password:

If you do not know your club / Safe Sport administrator password, please contact your club administrator or reach out to Sport Development at USA Swimming (SportDevelopment@usaswimming.org) or (719) 866-3567.

[EDIT CLUB PORTAL / SAFE SPORT LOGIN](#)

10

Club Portal Add Additional User Safe Sport Access

Step 11. In the Club Portal click on the “Users” tab



Step 12. Click on “Add

New Account”

Step 13. Enter in the user name and email address

- A password will be automatically generated, or you can choose to overwrite the password to one the user wants
- Do not assign the same password used for the administrator to another user. Either use the auto generated password or pick a different password for their use

Step 14. Click Save

Home Announcements Practice Schedules Upcoming Meets Meet Results Facilities Reports Users

USER ACCOUNT ADMINISTRATION

CLUB PORTAL ADMINISTRATION - SAFE SPORT ADMINISTRATOR ACCOUNTS

- To add a new Safe Sport Administrator account, click on the "Add New Account" button.
- A system generated password will be provided.
- You can enter a new password. The password must have 8 characters, 1 upper case, 1 lower case and 1 number.

[ADD NEW ACCOUNT](#) 12

ADD/EDIT USER ACCOUNT 14 [SAVE](#) [CANCEL](#)

Last Name: 13
First Name:
Email:
Password:

Step 15. Navigate back to the "Home" Tab

Step 16. Make sure to log out of the club portal by clicking on "Leave Club Portal Editor Mode"

Home Announcements Practice Schedules Upcoming Meets Meet Results Facilities Reports Users

CLUB INFO

CLUB PORTAL ADMINISTRATION

You are currently logged into the Club Portal in Edit Mode. While in edit mode you can do the following:

- Create or update your club portal. To begin, [Click Here](#).
- Add, edit and delete Announcements. To begin, click on the Announcements tab above.
- Add, edit and delete Practice Schedules. To begin, click on the Practice Schedules tab above.
- Add, edit and delete Upcoming Meets. To begin, click on the Upcoming Meets tab above.

NOTE: The Meet Results tab will pull all available meets and results from USA Swimming's times database unless you uncheck the "show meet results" checkbox which you can find by clicking on the link next to "Create or update club portal" above.

[LEAVE CLUB PORTAL EDITOR MODE](#) 16